

MS-E2177 - SEMINAR ON CASE STUDIES
IN OPERATIONS RESEARCH

TEAM UPM CARBON

System Dynamics Modelling of Forests as Carbon Sources and Sinks

FINAL REPORT

Cosmo Jenytin
Sonja Kokkonen
Roni Sihvonen (Project Manager)
Joanna Simms
May 25, 2020



Contents

1	Introduction	3
1.1	Background	3
1.2	Motivation	4
1.3	Objectives	5
2	Literature Review	5
2.1	System Dynamics	5
2.2	Education	6
2.3	Forests and Environment	7
3	Model Building & Data	7
3.1	Model Description	7
3.2	Data Collection	8
3.3	Assumptions	10
3.4	Model Building	11
3.4.1	Forest Growth Dynamics	13
4	Results	16
4.1	With Default Final Felling	16
4.2	With Larger Final Fellings	18
5	Discussion	20
5.1	Scenario Analysis	20
5.1.1	Growth and Carbon Sequestering	20
5.1.2	Energy Generated	21
5.2	Usability	21
6	Conclusions	23
6.1	Criticisms and Future Improvements	23
6.2	Final Summary	25
A	Appendix	33
A.1	Simulink Model	33
A.2	Substitutions	44
A.3	Demand Functions	45
A.4	Production Data Values and Sources	45

1 Introduction

1.1 Background

Forests, most broadly defined as large land areas dominated by trees, are “the dominant terrestrial ecosystem on Earth”, accounting for 80% of the total plant biomass and a habitat for the majority of species on the Earth [Pan et al., 2013].

Not surprisingly, forestry, silviculture, and the use of wood have a long history intertwined with the history and development of the human race. Wood has been an integral for developing the craftsmanship of modern humans, and wooden tools dating back as far as 400 000 years ago have been discovered [Radkau, 2012].

The modern forest industry grew spurred by a developing world and new raw material requirements. The Finnish forest industry, started in the 16th century, grew out of an increasing need to control the use of forests, as well as their preservation [Tasanen, 2004]. Our client organisation, UPM, has its roots in multiple different forest industry companies dating back to the 18th century [UPM, 2019].

Today, the forest industry is mainly divided into two parts, the mechanical and chemical forest industries [forest.fi]. The mechanical forest industry includes products made directly from wood, whereas the chemical forest industry refers to products (pulp and paper) made using wood raw materials and chemicals.

The forest industry and its products are becoming increasingly interesting due to their possible impact on climate change. The “warming of the climate system is unequivocal” and “unprecedented”, with the impact of agriculture, forestry and other land use (AFOLU) being a significant source of emissions. In 2010 24% of greenhouse gases released came from AFOLU [Pachauri et al., 2014].

The forest industry, and its products’ impact on climate change, can be viewed both directly and indirectly. Although forestry’s direct impact is significant and it has been said that in forestry the “most cost-effective [climate change] mitigation options are afforestation, sustainable forest management and reducing deforestation” [Pachauri et al., 2014]; forestry and the forest industry can have also positive impact indirectly through substitution. This is when forest industry products are used instead of products made by fossil fuels or other greenhouse gas (GHG) intensive materials.

In order to compare the climate change effects of different industries and products, one has to look at the whole life cycle of a specific product: from raw materials and production, to its use and possible recycling, then finally to its disposal as waste. To assess the climate change impact of such a life cycle, one can calculate the total CO₂ emissions (or CO₂-equivalent (CO₂-eq) emissions, i.e. the amount of CO₂ “emission[s] that would cause the same integrated radiative forcing, over a given time horizon, as an emitted amount of a greenhouse gas (GHG) or a mixture of GHGs” [Pachauri et al., 2014], where radiative forcing (RF) is used to quantify the strength of climate change drivers).

1.2 Motivation

This project addresses the world’s biggest problem at the moment - resource mismanagement (United Nations, European Union [2019b], Allen et al. [2019]). The substitution effect, as the central aspect of this project, has massive potential to rectify this mismanagement, as a mass of studies shows, (Leskinen et al. [2018], Ruuska [2013], Hillman et al. [2015]).

Although the scope of this project does not allow the opportunity to fully delve into cross-disciplinary areas (such as recycling policy, forest management, public behaviour, fuel usage and more) it highlights the interconnections to be developed further in the future by the respective experts in these fields. An example of these interconnections “the paper, glass, metals, plastic, and organic material Stanford recycled in 2016 saved a total of about 70,481 million BTUs of energy; enough energy to power nearly 613 homes for one year. Or said another way, conserved 12,131 barrels of oil or 567,3014 gallons of gasoline.” [Stanford]. These related disciplines ultimately determine the extreme points of our model, as well as being where the theoretical knowledge gained in this project will come into fruition.

To develop coordinated policies between disciplinary areas, all parties need to understand the entire process, which is where this project aim to have the greatest impact - education. This way a forest owner can make an educated choice as to whether their forest is better left standing or being part of the forest industry. The public misinformation or prejudice is very prevalent in resource management with different schools of thought. The main theme investigated is the difference between viewing the forest as simply a carbon sink - or whether to use it as a material source with no waste [UPM, b], [Bastin et al., 2019]. This emphasises the fact that we don’t just need to research the substitute effect itself, but teach other people about the powerful changes that could happen if they change their role in this system.

1.3 Objectives

UPM is one of the biggest operators in the Finnish forest industry [Metsäteollisuus, 2019]. Forests are massive carbon stocks and understanding the climate effects of forestry, or any other industry for that matter, is now more important than ever. The objective of this project is to use system dynamics to model the carbon cycle in forestry. More specifically, the idea is to model the entire Finnish forest industry and biological Finnish forests (opposed to political forests). This is done by developing an interactive tool to help us understand what kind of effects different features, parameters and products have on the net impact of carbon emissions.

There are plenty of open questions related to forestry and the carbon cycle: To what extent is using forests more efficient than conserving them? What is the net impact of different actions? In which cases are forest based products better than their substitutions? These are only a few examples of the motivating questions behind this project.

Another objective is to educate UPM - to improve conceptual understanding and support the sustainable aims of the company. As mentioned before, the model will be interactive, with the possibility to compare different products and scenarios. The interactivity and visual figures of the model support the educational aspect of the project. The target audience for the model is a layman or a UPM worker.

2 Literature Review

Due to the broad scope for this project, the literature review was an important re-scoping process. The main bodies of literature to investigate were; system dynamics, educational tools and forest literature.

2.1 System Dynamics

System dynamics (SD) is a way of investigating the relationships within complex and dynamic systems, by following a substance as it goes through a set of processes [Senge, 1990]. SD is used to model the behaviour of these systems through its feedback processes, i.e. positive and negative feedback loops, different relationships (e.g. flows) and elements of complexity (e.g. stocks, delays) Sterman [2001]. The systems are usually depicted with visual tools, that package the important information into a clear layout. The standard example of this is using a stock and flow diagram, with arrows representing flows and blocks representing stocks (see Figure 2). The visual aspects make

dynamic models easier to interpret over time than a spreadsheet calculation. Dynamic modeling also gives the opportunity to investigate co-dependencies, which spreadsheets cannot work with [Yearworth, 2014].



Figure 2: Example of a Stock and Flow Diagram

“System dynamics offers a consistent and rigorous problem-solving framework for identifying the scope of the problem, eliciting participant views about problem causes and system connections and identifying policy levers.” [Stave, 2002]. Due to this SD, as a mathematical basis, has allowed for iterative development; so that our scope has been refined over the process. It gave the opportunity to add detail as we saw fit, but to also have a complete, if simplified, overall picture relatively early in the project.

2.2 Education

SD is a valuable educational tool as it introduces the user to an entire system, giving a complete understanding of a process from cradle to cradle, or grave (depending on the recycling possibilities of the product) [McDonough and Braungart, 2010]. However, this system view has to be coupled with user interaction to give an experimental learning experience from each stage of the system and a deep understanding of the dependencies between processes. Stave [2002]’s paper “Using System Dynamics to Improve Public Participation in Environmental Decisions” highlights how an individual’s theory, from members of the public aiming to improve the air quality in Las Vegas Nevada, could be tested without diverging the topic of the meetings as the model will always concentrate on the discussed area. It also helped people understand their different roles in the system [p144].

The advantages of any mathematical model should be accessed via a suitable user interface to make it a proper educational tool. There are many carbon dioxide calculators open to the public, namely; Hiilijalanjalkilaskuri [University of Helsinki, 2019], the American Environmental Protection Agency United States Environmental Protection Agency (EPA), etc. However, these and many other calculators with a strong scientific basis are based on an Excel format which is hard to understand and not intuitive. “Autokalkulaattori” [Suomen ilmastopaneeli and Suomen ympäristökeskus SYKE, 2019]

– although having thorough references and the ability to change all of the parameters – strikes the balance between being an expert and beginner by first using the tool with the basic settings, but giving the option to expand the parameter options. This gives versatility as well as makes it easy to use for the user.

2.3 Forests and Environment

Forestry, the forest industry, and the use of the industry’s products make up a complicated dynamic system; therefore SD is well-suited for modeling them. Due to their ability to model complex systems, SD methods have already been successfully used to model the climate change impacts of forests (e.g. Härkönen et al. [2019]; Bonan et al. [2003]; Machado et al. [2015]) as well as for carbon footprint modelling of different products and processes (e.g. Trappey et al. [2012]; Shrestha et al. [2012]) and for climate policy makers (Fiddaman [2007]). SD methods are especially well-suited for modelling processes and supporting decision-making in matters which are complicated and important such as environmental decisions (e.g. Stave [2002]).

Machado et al. [2015] developed a model for monitoring and evaluating forest growth with SD and quantifying wood stocks and sequestered carbon. They found that by shortening the harvest cycles suitably, it is possible to obtain a gain of up to 21.0% in the sequestered CO₂ stock in forests. Coulston et al. [2015] used land use and forest inventory data to estimate how forest carbon dynamics have changed in the southeastern United States. They found that net decreases in forest carbon stocks caused by cutting were offset by forest growth. In addition, estimated carbon stock changes indicated slowing of carbon accumulation with anticipated forest aging.

3 Model Building & Data

3.1 Model Description

To facilitate the development of our model, we have had regular meetings with our client UPM. Right from the start, it has been clear that the project goals should be developed together with the model, and therefore there can be no definitive requirements on the model or answers to many questions. Thus we have worked iteratively, with each version giving more insights for the client and allowing them, and us, to come up with new interesting ideas and define a clearer direction for the project.

The basic structure of our model is illustrated in Figure 3. The left-hand side describes forest products, and the right-hand side their substitutes. The arrows represent transmissions of carbon along the process. The substitute products are not directly a part of the carbon cycle in forestry, but they are taken into account whenever the product demand is not fulfilled with only forest products.

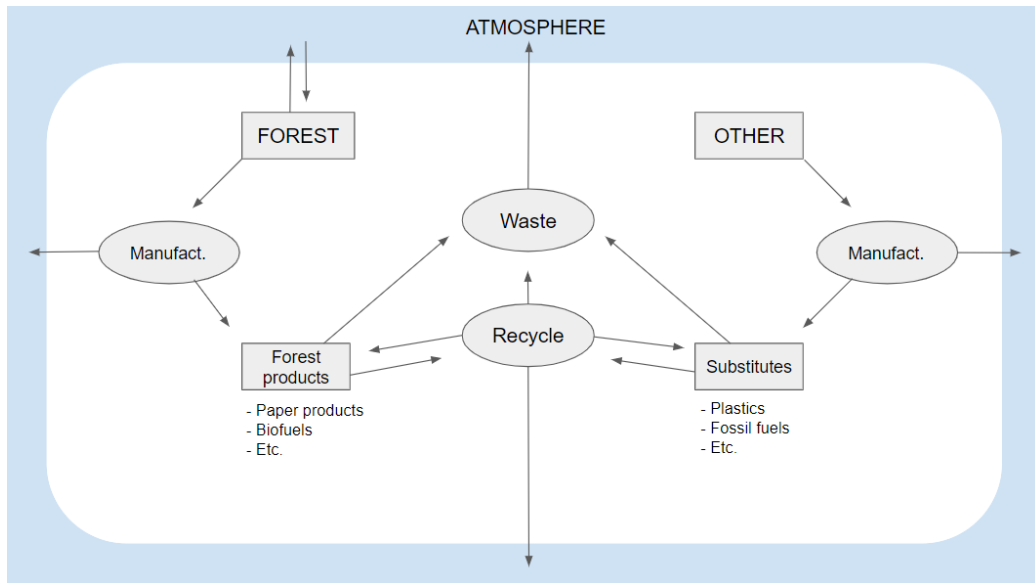

Figure 3: The basic model structure and procession of carbon.

In the model, forests function both as carbon sinks (e.g. via forest growth) and sources (e.g. via respiration). Forests are felled when there is demand for forest products, and the carbon stored in trees is transferred to the products. Manufacturing these products cause exogenous CO_2 emissions. Manufactured products can later be used to fulfill the demand by recycling, which also causes exogenous CO_2 emissions. If not recycled, the products become waste, and the carbon in them is eventually released back to the atmosphere by burning. The process is similar for the substitute products, but their material sources do not function as carbon sinks nor sources.

3.2 Data Collection

For the data collection for this model, we have consulted a broad range of sources to achieve a thorough understanding of the many subsystems in material production and recovery; this has given us information about the processes to be included in the model.

To produce a complete set of data and a successful model we focused on the forest industry in Finland as detailed information is available from Luonnonvarakeskus [2019], Metsäteollisuus and UPM [a]. This meant we could also assume the waste processing and material recovery scenarios are consistent with the Finnish systems; which also includes a substantial amount of open data. This process of modelling the Finnish situation meant we could not consider exportation of the products made in Finland causing, a discrepancy between Finnish production and consumption, which are considered equal for this model. This allowed the system to not be over-complicated with world wide recycling rates and end landscapes for each product and country.

The future production was computed with linear and nonlinear (exponential) regression with the sum of squares method (for formulas see Appendix A.3). This was performed on historic data (from Luonnonvarakeskus [2019] and Fastmarkets RISI) ranging from 65 to 15 years in length. The predictions were made using up to 80% of the earlier data (depending on the size of the data-set). Later points were used as validation of the trends confirmed with the root mean square error method, where smaller values are confirmation of the models prediction. These methods provide statistically significant trends for the next 100 years, which work as an educational baseline.

Scaling has been used on the paper functions to increase the harvest to the levels recorded by Luonnonvarakeskus [2019] – around 80 million meters cubed, including natural losses. All types of paper have been scaled as this will account for pulp products not included in our model, including pulp itself. The predictions of paper production and demand is therefore higher than would be expected, accounting for the use of pulp in used in other products other than paper, but under the paper label. This limits the model in terms of accurate market forecasts, but does provide a scientific basis and inclusion of an increased demand, production rate and consumption rate which will occur and could interact with the possible production of forest products.

Life-cycle CO₂ emissions have been calculated for the stages of a product's life, which are considered as parameters in our model (growing of trees, manufacture and recycling). UPM data is used for the forest products. The substitution products are calculated from contrasting international databases (Phyllis2 [2020], Plastics Europe, United States Environmental Protection Agency (EPA)), companies and other comparison studies. When other sources are used the priority was given to UPM, Finnish research, European research, product databases and finally world research; particularly IEA (International Energy Agency) and EPA (Environment Protection Agency –

United States Environmental Protection Agency (EPA)), respectively. See the complete set of data and sources in the Appendix A.4. Values from these international data sets are also included in many material comparison studies (Hillman et al. [2015], Ruuska [2013]) and mean averages are usually taken to balance out the more extreme sources. To keep the emissions as consistent as possible the electricity CO₂ emissions coefficient given by UPM open data was used at all times. This number represents the Finnish grid. When we encountered both energy consumption and CO₂ emissions for a process, energy values were used. However, when energy consumed was not given, all data was gathered for verification of the data. Another form of validation was our UPM mentors working with us to provide us with sensible end landscapes and predictions.

Some subsystems could not be included due to a lack of complete data sets. One of these is that recycled items do not necessarily recycle back into the same product. In terms of paper the fibres get shorter each time they are reprocessed meaning they must downgrade each time they are recycled [Technical Association of the Pulp & Paper Industry Inc., 2001].

3.3 Assumptions

Model building can be very complicated and to create a viable model – and avoid an overly complicated one – we made some assumptions and simplifications. This was done after doing research and discussing what are the most relevant things in the model and what kind of things can be simplified.

As mentioned in the previous chapters, the model represents Finland and Finnish forestry. Due to the lack of precise data and to not exceed the extent of this project, the model uses aggregate numbers such that all Finnish forests are considered as a single homogeneous forest. This means that different tree species, locations, densities and ages are not taken into account, in other words we assume that they are the same everywhere. For the same reasons, these factors are not taken into account when modeling the forest growth, apart from growth which is assumed to be a function of average age of forest. This is discussed more closely in Section 3.4.1.

When substitutions are made, we assume that the demand is first met by the forest products until the harvesting limit. The rest of the demand should be filled by the substitute products, which are assumed to come from an infinite source. In other words, there is not limit to the amount of products that can be made from the substitute material.

The values for the recycling shares are mean averages of Finnish recycling

data from 2018 [Tilastokeskus, 2018]. The recycling options are categorized into material recovery, energy use and incineration of waste. As a simplification, no landfill is taken into account and thus the amount of waste going into landfill and other disposal is included in the incineration of waste. As the data set used for analysing recycling shares does not specify the meaning of material recovery, it has been assumed that material recovery implies that each product becomes the same kind of product in the recycling process, which is a simplification for everything aside from aluminium and glass. In a perfect model, other materials would downgrade when recycled.

The consumer recycling rate used in the model is 100% – this means that the economy is entirely circular and no consumer error is taken into account. The EU within the “The European Green Deal” road-map has set a target in which EU will reach a resource efficient nearing circular economy and net zero emissions by 2050 [European Union, 2020]. This, however, also depends on material recovery rates. Although we have assumed that consumer rates will be 100%, the material recycling efficiency is assumed to stay at the current rate, as this would involve predicting technological advances in the next 100 years which is simply not possible with our expertise. This means the model returns a lower limit for plastics and paper recycling.

We are not considering the dynamics of economy. Producing, as illustrated above, has been transformed by a factor into demand. This is a reasonable assumption for the more temporary products e.g. paper, packaging and bio-fuel. For the more permanent products (plywood and sawn goods) we assume that the products being produced match the older products that are going to waste handling. A specific example is that the amount of new plywood put into a building will match the old plywood that is being replaced.

The model assumptions, values and equations have been set after doing research and analysis of plenty of data sources. Using several data sources is good for verifying and validating the model. On the other hand, some of the data is company data which may not be objective. Therefore the model should be used only for educational purposes, not as a scientific tool.

3.4 Model Building

The model was built in MATLAB’s Simulink, since it is suitable for simulating dynamic systems and previously familiar to us. The approach for this project was iterative not just in terms of modelling, but also in determining what new data parameters need to be added to the model. This continuous process of incremental data analysis gives the model a strong theoretical

basis as we always refer and respond to the relevant literature.

The general process followed is indicated below

1. Carbon cycle from the atmosphere to forest, production of forest products, recycling, waste handling and back to the atmosphere
2. Defining a few products
3. Experimenting dynamic product demands
4. Adding simple recycling (material recovery)
5. Adding substitutions
6. Experimenting forest growth dynamics
7. Adding more realistic recycling with material and energy recovery and incineration
8. Adding more and realistic products
9. Adding more realistic two-phase production, with solid wood and pulp production
10. Adding dynamic demand predictions based on fitted functions
11. Building a graphical user interface (concurrent with many of the phases above)
12. Validation and Sensitivity Analysis, bug fixing, final touches

Figures 9 to 13 in Appendix A.1 show the development process of the Simulink model. Many of the changes are of course more detailed within the specific subsystems. The final and full model is shown in Appendix A.1 in Figure 14, and Figures 15 to 26 show the subsystems of this full model.

This building process was presented to UPM during each meeting we had and went mainly to plan. The only general points to raise in the making of the model were the appearance of “algebraic loops”, i.e. “circular references” (e.g. supply of forest derived products determines the demand of substitute and forest derived products, which then determine the supply of them, etc.). Simulink has ways of automatically solving these algebraic loops, but to compile a standalone executable simulation, which was our goal, we had to introduce new dynamics in order to break these loops. This was done by adding “transport delays” to the model to add a slight delay so processes that influenced and interacted with each other didn’t happen at the same time. These algebraic loops do not cause big problems to the results and

transport delay blocks were added to keep the model continuous, with delays of 0.1 time units (years), which is a small delay compared to the dynamics of the model (demands changing on an annual basis), so they did not influence the results unduly, and in fact made the model even more realistic (since recycling of products can be assumed to happen only after they have been produced).

Having said this these algebraic loops were avoided if possible. This meant that when, during testing, we discovered that the recycling of substitute products was not accounted for in the demands of the forest this was not fixed. This leads production to be slightly over-estimated for substitute products with high recycling rates – e.g. aluminium. This only causes small discrepancies in the results as the amount of aluminum in the system is relatively low and stays stable after the initial production, due to the high recycling rate (99.9%).

Where possible the model was validated with historical data [Luonnonvakeskus, 2019]. However, details were sometimes overlooked, for example the forest age structure. Although it would have been possible to develop this into the model, there is little information available to validate the model. This is a good example of how the data we gathered had real scoping properties even during the model development.

3.4.1 Forest Growth Dynamics

There exist many growth functions that have been used to model growths of trees and forest stands as a function of age (see e.g. [Zeide, 1993] and [Burkhart and Tomé, 2012]). In our model, we are adapting the so called Gompertz function

$$g(t) = ae^{-be^{-ct}}, \quad (1)$$

where $g(t)$ is the wood volume per hectare of forest stand at time t ; a is an asymptotic parameter corresponding to the maximum volume per hectare, and b and c describe growth rates. When modelling large forests that can be harvested, age structures of forests can change and the same age does not necessarily correspond to the same volume. Hence, instead of using the Gompertz function (1) as such, we are using its derivative

$$g'(t) = abce^{-be^{-ct}-ct}. \quad (2)$$

Thus, we assume that the yearly volume growths per hectare are the same for forests of the same average age. The Gompertz function was chosen because it has already been used to model forest growth in system dynamics [Machado et al., 2015], and seemed to fit our data well.

We used data from Luonnonvarakeskus [2019] for the annual growths per hectare and to calculate the average ages of Finnish forests. This data is shown in Table 1. The Gompertz function was fitted to the age-growth data in MATLAB using the `lsqcurvefit()`-function, which uses the least-squares method to estimate the function parameters b and c . The value for parameter a was chosen based on the statement by Pukkala [2017], according to which the wood volume in Finnish forests could be at least tripled compared to the current volume. According to Luonnonvarakeskus [2019], the volume of timber in Finnish forestlands and the area of forestlands were 2409 (mill. m³) and 20.276 (mill. ha), respectively, in 2014-2018. Thus, $a \approx 3 \cdot 2409 / 20.276 \approx 356$ (m³/ha).

Table 1: Average ages and annual growths of Finnish forests [Luonnonvarakeskus, 2019]

Timespan	Average Age (years)	Growth (m ³ /ha/year)
1964-1970	73.82	2.9
1971-1976	70.33	2.9
1977-1984	67.79	3.4
1986-1994	65.94	3.8
1996-2003	64.59	4.2
2004-2008	62.01	4.9
2009-2013	61.66	5.1
2014-2018	61.49	5.2

As the interval of the estimated average ages [61.49, 73.2] is quite small in respect of the shape of the Gompertz function, we used leave-one-out-cross-validation (LOOCV) to test the robustness of the fit. That is, in addition to fitting the Gompertz function to all the data points, we left each of the data points away one at a time, and fitted the function to these subsets of the data. The data points and all the fitted curves are plotted in Figure 4.

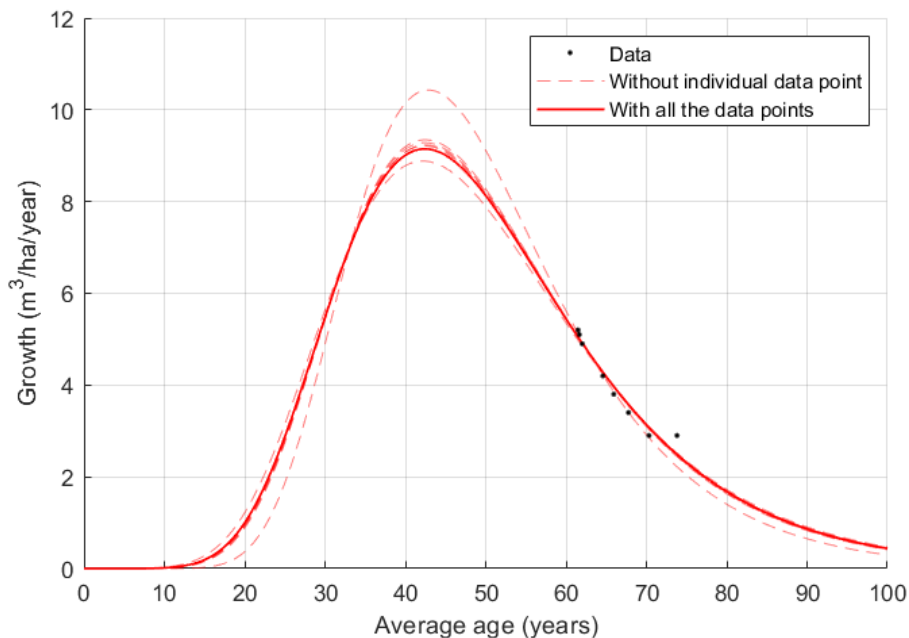

Figure 4: Data points and curves of the fitted functions (2).

The estimated values are $b \approx 19.3$ and $c \approx 0.0698$ when using all the data points. We can see that leaving individual data points out does not affect the curves drastically, especially with values close to the most recent average age of approximately 61.5 years. The biggest difference happens with the largest growths. The greatest total growth according to the fitted curve would be approximately $9 \text{ m}^3/\text{ha}/\text{year} \cdot 20.276 \cdot 10^6 \text{ ha} \approx 180 \text{ mill. m}^3/\text{year}$. According to Mäntyranta [2016], the annual growth of Finnish forests could be 150 mill. m^3 , so we assume that there is no need for the greatest theoretical growth to be more than 180 mill. m^3/year . Thus, the function fitted using all the data points is considered satisfactory for our model.

In the model, the forest can be harvested either by thinning or final felling. Only the latter has an effect on the average forest age, and the default value for final felling is 22% of total harvesting. These are based on our meetings with the client. In addition to final felling, the natural loss of forests can decrease the average age. Because we do not know the precise age structures of the forests being harvested or lost, we simply assume that $x\%$ of final felling and natural loss from the total forest volume decreases the average age by $x\%$. This might be a strong assumption, hence we run the simulations with different final felling percentages to see the effect of forest age on the results.

4 Results

The default values used in the model are shown in Table 2. Where necessary the values are further referenced in the appendix.

Table 2: Default Values for the Simulation

Variable	Value	Reference
Simulation Time	60 years	UPM Advice
Harvesting Limit	3.42%	Luonnonvarakeskus [2019]
Predicted Demand Functions	See Appendix A.3	Luonnonvarakeskus [2019]
Sawn Wood ^a	11330000 m ³	Luonnonvarakeskus [2019]
Plywood	1090000 m ³	Luonnonvarakeskus [2019]
Packaging Paper Substituted by LDPE	24000000 tonnes	Fastmarkets RISI, Scaled by 20
Packaging Paper Substituted by HDPE	24000000 tonnes	Fastmarkets RISI, Scaled by 20
Packaging Paper Substituted by Glass	24000000 tonnes	Fastmarkets RISI, Scaled by 20
Packaging Paper Substituted by Aluminium	24000000 tonnes	Fastmarkets RISI, Scaled by 20
Graphic Paper	90760000 tonnes	Fastmarkets RISI, Scaled by 20
Tissue Paper	3240000 tonnes	Fastmarkets RISI, Scaled by 20

^a Values for woods and papers are initial demands.

4.1 With Default Final Felling

The simulations were run using the sustainable harvesting limit as in Table 2 and with the harvesting limit being 0%, which would mean that there is no forestry and only substitute products are used. As a result, Finnish forest volume, atmospheric CO₂, annual drain (i.e. total harvesting and natural loss of forest), average age of the forest and total energy generated by burning the waste were plotted.

The results of the simulations when using the default final felling percentage of 22% are shown in Figure 5.

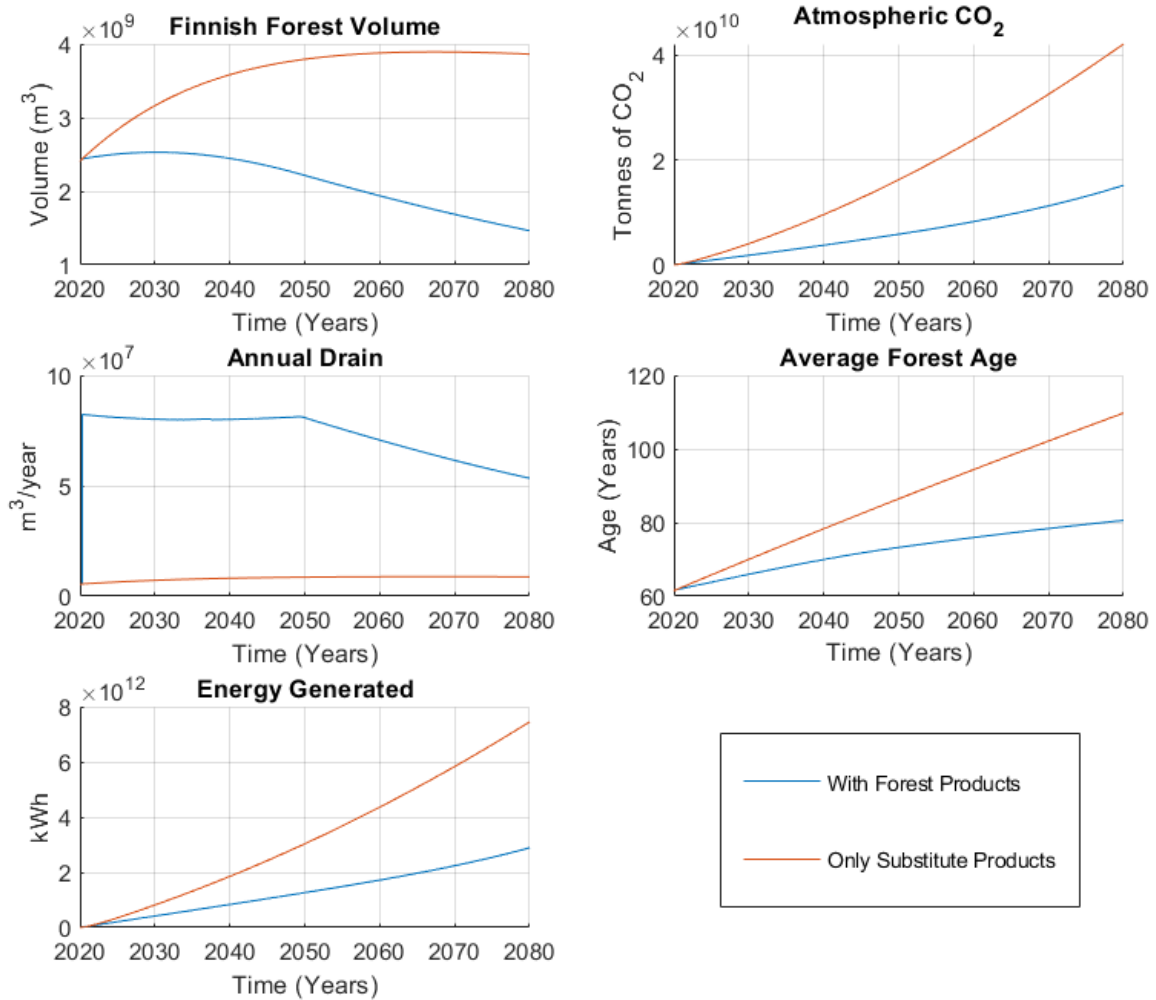

Figure 5: Results of the simulations when using the default final felling percentage.

We can see from Figure 5 that the forest gets older which causes the forest growth to decrease according to the growth function in Figure 4. The forest volume decreases until the sustainable harvesting limit is achieved after approximately 30 years. This does not seem realistic, as according to Luonnonvarakeskus [2019] the Finnish forest volume, annual harvesting and annual growth have been increasing during the last decades while the average age has been decreasing. Even though the 22% final felling might be close to the real value, it seems to make the results unrealistic in this model. Thus,

to test the sensitivity of the model, the same simulations will be run with larger final fellings as well.

4.2 With Larger Final Fellings

The same simulations were run using the final felling percentages of 50% and 80% to see how the age of the forest affects the results. These percentages were chosen arbitrarily. The plots from these simulations are shown in Figures 6 and 7, respectively.

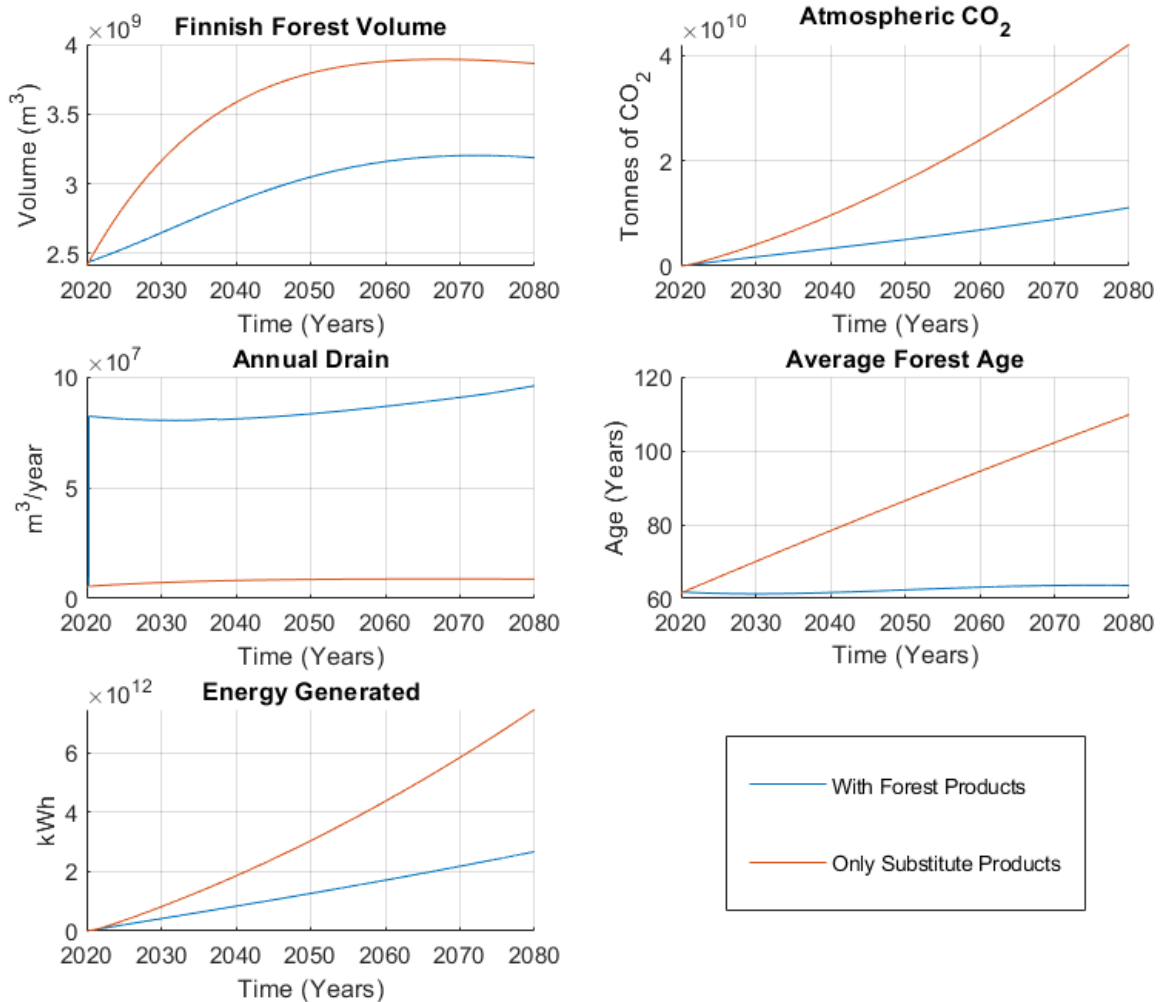

Figure 6: Results of the simulations when final felling is 50% of total harvesting.

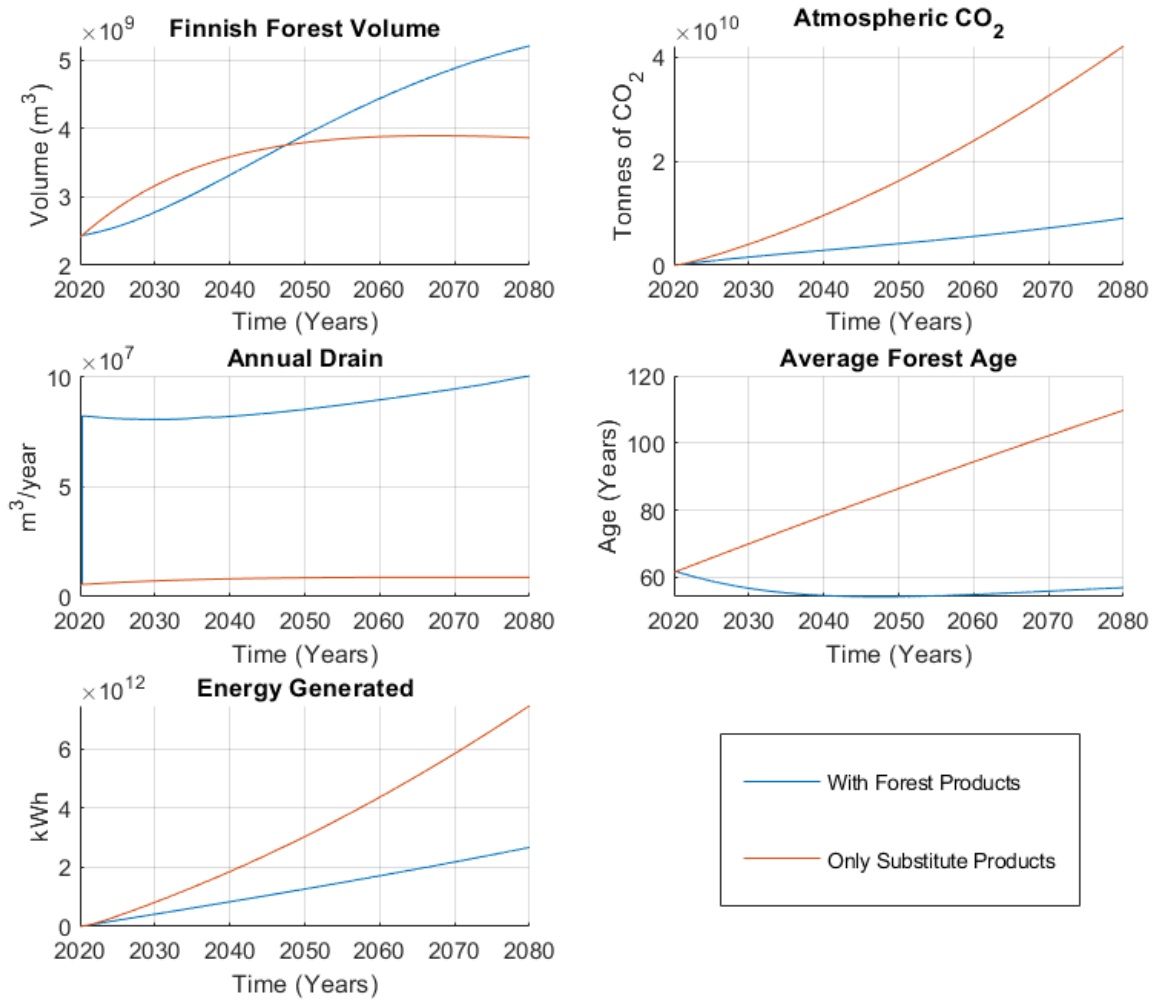

Figure 7: Results of the simulations when final felling is 80% of total harvesting.

Figures 6 and 7 indicate that larger final felling percentages make the forest younger on average, as they should. Younger forests grow more making the forest volume bigger, and thus the harvesting limit is not achieved and the demand can be fulfilled with forest products.

5 Discussion

5.1 Scenario Analysis

5.1.1 Growth and Carbon Sequestering

By leaving the forest to grow i.e. making all products from their respective substitutes, more CO₂ emissions are released into the atmosphere. Forest products have lower life-cycle costs compared to the other materials in this study, further contributing to the effect of forest products releasing less emissions. This is in accordance with Pachauri et al. [2014], who stated that forestry and forest industry can have a positive impact on climate indirectly through substitution. After 60 years the atmospheric CO₂ released by substitute manufacture is around 4 times higher than the amount released with a sustainable harvesting rate. This is true across all final felling percentages. The annual drain is also consistently and significantly higher when forest products are produced, as without forest products the drain consists only of natural loss. Although the forest is able to grow more and thus sequester more CO₂ if forest products are not used (Figures 5 and 6), this does not make up for the difference in the life-cycle costs of the products produced. This effect is intermixed with the age of the forest.

By managing forests we are lowering the age, and therefore keeping the trees within the optimal sequestering age; where they absorb the most amount of CO₂. We see in Figures 5-7 that by harvesting forests, such that the age remains lower, the forest volume can increase more and thus forests can sequester more CO₂. This is in accordance with the papers by Machado et al. [2015] and Coulston et al. [2015] that stated suitable harvesting and younger forest age indicate better carbon accumulation, as described in Section 2.3. To keep the age of the forest lower, we should harvest it - a result agreed within greater literature e.g. [Pachauri et al., 2014]. However, we should also remember that to harvest for some forest products, such as sawn wood, the trees have to reach a certain width, and therefore age, to be useful.

Although using forest products does appear to release less CO₂ emissions than using purely substitutes, we also observe that the demand cannot always be fully supplied with only forest products. When using the larger final felling percentages and the predicted demand for the next 60 years, we do not need to use substitute products. This means that the forest is capable of supplying the amount of raw materials needed to make these products, without the need for substitute materials and without exceeding the current sustainable harvesting limit. This could be due to the effect of the forest

volume increasing more quickly with a smaller age; meaning there is more forest to produce from. This could be a factor of our representation of the forest growth. When the final felling is at the default level, the forest volume starts to decrease slowly, with the annual drain changing dramatically around the year 2050. This drop indicates that the production of forest products is growing quicker than the forest growth. This utilisation rate of the forest increasing over the growing rate agrees with other predictions of forest use with future demand of biofuel [Seppälä et al., 2019], but overall research is split on whether the future demand of the forests in Europe will increase over the growing rate Agency [2018].

When looking at a smaller plot of land, for example the average privately owned forest area: 30.5 hectares [Luonnonvarakeskus, 2019], we see the same patterns simply scaled down. This is intuitive as nothing has changed in the model apart from the number of trees.

Ultimately the suitable harvesting limit is also very sensitive as the difference between these two situations (using forest products or only substitute products) is 3.42% of the volume harvested. This value is not only dictated by CO₂ levels, but biodiversity amongst other factors meaning it has not been investigated in this study - it is enough to note the sensitivity.

5.1.2 Energy Generated

The energy generated from burning products is larger when considering the substitute products rather than just forest products. This could be because plastic products have a higher energy potential as well as a lower recycling rate leading to more products being burnt for waste. The numbers are also large due to the Finnish energy recovery rates from waste being so high compared to plain incineration (see Appendix A.4).

The energy generated from the system in terms of the forest products with the default settings matches the Luke historical data, i.e. 15,172 TWh produced by Finland in 2019 [Luonnonvarakeskus, 2019]. The Luke value includes some wood being directly put into energy, not only as energy produced by waste of the process.

5.2 Usability

The GUI is quite intuitive, with switches, sliders and tabs to separate different sections, and boundaries to prevent the user from being able to set the values dramatically out of our range. System dynamics works best close

to the baseline, and limiting options in certain places makes it possible to keep the user in a numerical domain for which there is more confidence. This means that the results are more accurate in this region as the data, research and our developments have been done in this area. In reality, systems tend to adapt when we get closer to the limiting factors, which is something our model does not take into account.

The GUI allows the user to change the simulation time, the harvesting limit and final felling percentages, and the initial product demand values. In addition, the user can choose whether to use predicted future product demands or constant products demands.

Running the simulation generates the results as separate plots, each of which containing both the scenario where we use forest products within the sustainable harvesting limit, and the scenario in which only substitute products are used. As the two scenarios are plotted into the same graphs, it is easier to compare which scenario seems better. As shown in Figure 8, the GUI includes four tabs. The first three tabs include the plots, and the fourth one includes summarized information about the model data and assumptions.

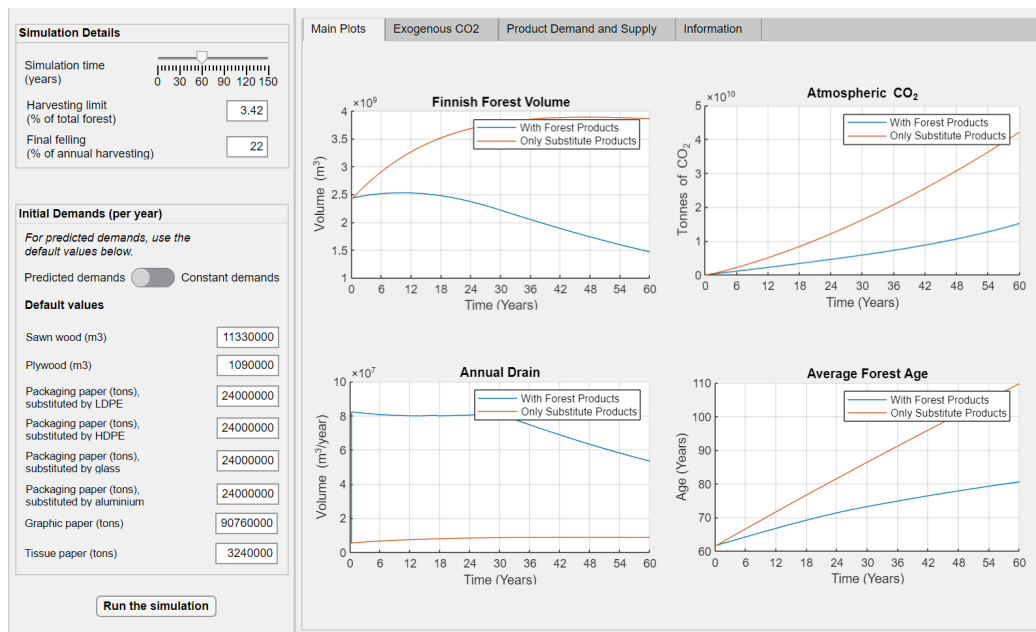

Figure 8: The graphical user interface.

As for the usability of the GUI, the interface has been designed as intuitive as possible. In addition, the interactive parameters are chosen so that the results

are interesting and realistic. However, there was no experimenting within test users and hence, we did not get any constructive feedback for the GUI as we originally planned. This was partly due to the unusual circumstances, later discussed in detail.

6 Conclusions

6.1 Criticisms and Future Improvements

Ultimately the situational factor of the COVID-19 virus meant that some university technology was not available, as well as the time lost by the complications of remote working on our and UPM's behalf. This means that the limited resources we had for this project (as a 5 credit university course) became slightly slimmer. Luckily, this had no large impact in the development of the model, due to the very open brief, however further development could have been made in any one of the areas mentioned in this section as well as being able to test the application on a test group.

When making such a complex system into a mathematical model, many simplifications and assumptions have to be made. In terms of our assumptions some are more influential than others. After sensitivity analysis we can see that the final felling and therefore age of the forest have a considerable effect of the forest growth, meaning the addition of different forest structures could have a noticeable effect on the above results. The demand or production can also create discrepancies, because working with limited open data and not considering all forest products mean that the demand rates had to be modified to fit a real world harvesting rate. Furthermore, there are challenges in extrapolating data over 100 years.

Some features that could have given a greater picture of the entire problem would be to make the system more symmetrical with more on the source for every material in the system, not just the forest products. This could be achieved by defining more subsystems/blocks such as differing manufacture processes, material supply limits and separate transportation costs. Recycling is another detailed system that could be expanded, including the recycling of a product into a downgraded product, having different recycling technologies and allowing efficiency to change over time. However, adding details to the model would move away from an educational tool into a scientific one, which was not our objective.

The available data for this project is from wide ranging sources. These varied sources give room for error and meant that some subsystems could simply

not be included. Although it also permits constant validation of the data we are gathering, it would be of interest to investigate how differently the model behaves if we were to use a consistent data sources which are currently behind pay walls or confidentiality certificates (e.g. a company’s own data or the data from places like Ecoinvent [2019], Fastmarkets RISI, Suhonen and Amberla).

Rather than using the production values and scaling, having demand data and more products would have meant that our need to scale these production values would be much lower. Although scaling is more often than not needed in these studies, some of the scaling could be avoided.

Another nice feature to add in further iterations would be the ability to change the fuel source for each process (i.e. biofuel powered manufacturing and recycling). Currently the emissions used are from the average Finnish electricity grid. However, what would happen if the make up of the grid changed? What if processes became less fuel intensive in the future? Does this favour certain materials over others as their manufacturing cost might not make up for the CO₂ released by their energy recovery at the end? And would this energy recovered be needed? As we see, there are plenty of interesting questions to be answered still.

In terms of the forest parameters we have only considered a generic tree rather than taking species, and products from said species into account. An interesting avenue would be to allow for different types of species and different growing conditions, to be able to consider a worldwide view.

The worldwide view is important as ultimately CO₂ emissions are not limited to one country. Not only will imports and exports (in Finland’s case mainly pulp) of various materials have a CO₂ cost, the fuel make up of the manufacture process will differ per country implying different emissions within this. Infrastructure is also not equal in each country - recycling infrastructure is lacking in the developing world as well as in some European countries [World Bank, 2019, European Environmental Agency, 2019]. Although this is changing, with an “Africa Plastics Recycling Alliance” created by leading companies such as Nestle and Coca-Cola to make recycling accessible in Sub-Saharan Africa [Diageo, Unilever, CocaCola, Nestle, 2019], the change is neither quick nor universal.

In our model we have, in essence, assumed that the same amount that is produced also goes to recycling each year. From the perspective of data flows, this means that like there is no delay between production and recycling, i.e. products get “instantly” recycled; products have no “lifetime”. This is

based on the assumption that the amount produced is approximately the same amount that is going to be destroyed that year and needs “replacing”, i.e. we assume the waste is already the average age of the products and the amount is equal to the amount produced. This is most likely roughly valid for products with short lifetimes (paper or plastic bags etc.), but may be unrealistic for products with a longer life span (e.g. construction materials) which can store carbon for a significant period of time. This is a simplification in our model, and an approach to remove this would be to add some kind of stock of products where they are stored for their life span using some delays (that must be product-specific) and only recycling the products when they have come to the end of their lives. This would of course require us to find the product-specific life spans or, for even more realism, find the average ages for different uses, giving a distribution of life times for each product.

We did not have time to experiment with users of the user interface due to time constraints. Had we had the opportunity, watching them interact with the interface would have taught us if the vocabulary we have been using is accurate and understandable. We would also have been able to verify if the model acts in a way that a UPM expert would consider logical, or at least as much as an educational tool can be, and in a way that a layman can understand. We could have also developed extra features that would interest the focus group.

6.2 Final Summary

Our simulation results show that the use of forest based products reduces the amount of CO₂ equivalent gases released to the atmosphere compared to substitute materials. This happens due to the relatively low life cycle emissions of the Finnish forest products as well as the forest having a younger age, and therefore staying at optimal sequestering age.

The results are fairly consistent across the different final felling percentages considered (see Section 4). However, the final felling percentage and therefore age of the forest has the most pronounced effect in the system.

The future wood demand and the inclusion of more products would greatly improve the accuracy of the model in terms of the production interacting with the sustainable harvesting limit.

Generally and educationally we have a scientifically based model of how the harvesting of the forest interacts with the levels of atmospheric CO₂, which, as with any model, could be improved with increased detail and the addition

of more subsystems as well as the controls to define all of these values being added to the user interface.

References

- E. E. Agency. Environmental indicator report 2018 in support to the monitoring of the Seventh Environment Action Programme, 2018. URL <https://www.eea.europa.eu/publications/environmental-indicator-report-2018>. Assessed 2020-05-22.
- M. Allen, P. Antwi-Agyei, F. Aragon-Durand, M. Babiker, P. Bertoldi, M. Bind, S. Brown, M. Buckeridge, I. Camilloni, A. Cartwright, et al. Technical Summary: Global warming of 1.5° C. An IPCC Special Report on the impacts of global warming of 1.5° C above pre-industrial levels and related global greenhouse gas emission pathways, in the context of strengthening the global response to the threat of climate change, sustainable development, and efforts to eradicate poverty. 2019.
- J.-F. Bastin, Y. Finegold, C. Garcia, D. Mollicone, M. Rezende, D. Routh, C. M. Zohner, and T. W. Crowther. The Global Tree Restoration Potential. 2019. URL <https://science.sciencemag.org/content/365/6448/76>. Accessed on 2020-04-27.
- G. B. Bonan, S. Levis, S. Sitch, M. Vertenstein, and K. W. Oleson. A dynamic global vegetation model for use with climate models: concepts and description of simulated vegetation dynamics. *Global Change Biology*, 9(11):1543–1566, 2003.
- H. E. Burkhart and M. Tomé. *Modeling Forest Trees and Stands*. Springer Science & Business Media, 2012.
- J. W. Coulston, D. N. Wear, and J. M. Vose. Complex forest dynamics indicate potential for slowing carbon accumulation in the southeastern United States. *Scientific Reports*, 5:8002, 2015.
- H. Dahlbo, T. Myllymaa, K. Manninen, and Korhonen. HSY:n alueella tuotettujen, käsiteltyjen ja hyödynnettyjen jätelajien khk - päästöker-toimet – laskelmien taustatietoa, 2011.
- Diageo, Unilever, CocaCola, Nestle. Launch of the Africa Plastics Recycling Alliance with Africa CEO Forum, 2019. URL <http://www.uniafrica.org/wp-content/uploads/2019/04/africa-plastics-recycling-alliance-press-release-26march2019.pdf>. Accessed 2020-05-04.
- Ecoinvent. Ecoinvent 3.6, 2019. URL <https://www.ecoinvent.org/database/ecoinvent-36/ecoinvent-36.html>. Accessed 2020-05-04.

- European Environmental Agency. Waste Recycling, 2019. URL <https://www.eea.europa.eu/data-and-maps/indicators/waste-recycling-1/assessment-1>. Accessed 2020-05-12.
- European Union. Establishing the EU Ecolabel criteria for graphic paper and the EU Ecolabel criteria for tissue paper and tissue products, 2019a. URL <https://eur-lex.europa.eu/legal-content/EN/TXT/HTML/?uri=CELEX:32019D0070&from=EN>. Accessed 2020-05-13.
- European Union. The European Green Deal, 2019b. URL https://ec.europa.eu/info/strategy/priorities-2019-2024/european-green-deal_en#timeline. Accessed on 2020-04-27.
- European Union. Circular Economy Action Plan, 2020. URL https://ec.europa.eu/environment/circular-economy/pdf/new_circular_economy_action_plan.pdf. Accessed 2020-05-04.
- Fastmarkets RISI. Forecasts. URL <https://www.risiinfo.com/service/forecasts/>. Accessed 2020-05-13.
- T. Fiddaman. Dynamics of Climate Policy, 2007. URL http://cmap.crs.org.pl:4444/rid=1245936828296_1127358638_196199/Dynamics%20of%20climate%20policy.pdf. Accessed 2020-05-04.
- forest.fi. Forest industry. URL <https://forest.fi/glossary/forest-industry-metsateollisuus/>. Accessed on 2020-02-24.
- S. Härkönen, M. Neumann, V. Mues, F. Berninger, K. Bronisz, G. Cardellini, G. Chirici, H. Hasenauer, M. Koehl, M. Lang, et al. A climate-sensitive forest model for assessing impacts of forest management in Europe. *Environmental Modelling & Software*, 115:128–143, 2019.
- K. Hillman, A. Damgaard, O. Eriksson, D. Jonsson, and L. Fluck. Climate Benefits of Material Recycling Inventory of Average Greenhouse Gas Emissions for Denmark, Norway and Sweden, 2015. URL <https://norden.diva-portal.org/smash/get/diva2:839864/FULLTEXT03.pd>. Accessed 2020-04-30.
- International Energy Agency. International Energy Agency. URL <https://www.iea.org/>. Accessed 2020-04-30.
- P. Leskinen, G. Cardellini, S. Gonzalez-Garcia, E. Humekoski, R. Sathre, J. Seppälä, C. Smyth, T. Stern, and P. J. Verkerk. Substitution effect of wood-based products in climate change mitigation, 2018.

- Luonnonvarakeskus. Ownership of forest land by forest funds increasing rapidly, 2019. URL <https://www.luke.fi/en/news/ownership-of-forest-land-by-forest-funds-increasing-rapidly/>. Accessed 2020-05-20.
- Luonnonvarakeskus. Statistics database, 2019. URL <http://statdb.luke.fi/PXWeb/pxweb/en/LUKE/?rxid=f8ed5f38-9607-4c55-91c9-791d660b234e>. Accessed 2020-04-29.
- R. R. Machado, S. V. Conceição, H. G. Leite, A. L. de Souza, and E. Wolff. Evaluation of forest growth and carbon stock in forestry projects by system dynamics. *Journal of Cleaner Production*, 96:520–530, 2015.
- W. McDonough and M. Braungart. *Cradle to cradle: Remaking the way we make things*. North point press, 2010.
- Metsäteollisuus. Tilastot. URL <https://www.metsateollisuus.fi/tilastot/>. Accessed 2020-04-29.
- Metsäteollisuus. Metsäteollisuus, 2019. URL <https://www.metsateollisuus.fi/tilastot/metsateollisuus/>. Accessed on 2020-02-24.
- H. Mäntyranta. The annual growth of Finnish forests could be 150 million cubic metres, 2016. URL <https://forest.fi/article/the-annual-growth-of-finnish-forests-could-be-150-million-cubic-metres/#57ff3566>. Accessed 2020-05-17.
- Nordic Ecolabelling. Tissue paper, 2011-2022. URL <http://www.nordic-ecolabel.org/product-groups/group/?productGroupCode=005>. Accessed 2020-05-13.
- R. K. Pachauri, M. R. Allen, V. R. Barros, J. Broome, W. Cramer, R. Christ, J. A. Church, L. Clarke, Q. Dahe, P. Dasgupta, et al. *Climate Change 2014: Synthesis Report. Contribution of Working Groups I, II and III to the Fifth Assessment Report of the Intergovernmental Panel on Climate Change*. IPCC, 2014.
- Y. Pan, R. A. Birdsey, O. L. Phillips, and R. B. Jackson. The structure, distribution, and biomass of the world’s forests. *Annual Review of Ecology, Evolution, and Systematics*, 44:593–622, 2013.
- Phyllis2. Database for (treated) biomass, algae, feedstocks for biogas production and biochar, 2020. URL <https://phyllis.nl/>. Accessed 2020-04-29.

- Plastics Europe. Eco Profiles. URL <https://www.plasticseurope.org/en/resources/eco-profiles>. Accessed 2020-04-29.
- T. Pukkala. Suomen metsissä on vähän puuta, 2017. URL <https://arvometsa.fi/blogi/suomen-metsissa-on-vahan-puuta>. Accessed 2020-05-17.
- J. Radkau. *Wood: A History*. Polity, 2012.
- A. Ruuska. Carbon footprint for building products ECO2 data for materials and products with the focus on wooden building products, 2013. URL <https://www.vttresearch.com/sites/default/files/pdf/technology/2013/T115.pdf>. Accessed on 2020-04-30.
- P. Senge. *The Fifth Discipline: The Art and Practice of the Learning Organization*. London Random House, 1990.
- J. Seppälä, T. Heinonen, T. Pukkala, A. Kilpeläinen, T. Mattila, T. Myllyviita, A. Asikainen, and H. Peltola. Effect of increased wood harvesting and utilization on required greenhouse gas displacement factors of wood-based products and fuels. *Journal of environmental management*, 247:580–587, 2019.
- E. Shrestha, S. Ahmad, W. Johnson, and J. R. Batista. The carbon footprint of water management policy options. *Energy Policy*, 42:201–212, 2012.
- Stanford. Frequently Asked Questions: Benefits of Recycling. URL <https://lbre.stanford.edu/pssistanford-recycling/frequently-asked-questions/frequently-asked-questions-benefits-recycling>. Accessed on 2020-04-07.
- K. A. Stave. Using system dynamics to improve public participation in environmental decisions. *System Dynamics Review: The Journal of the System Dynamics Society*, 18(2):139–167, 2002.
- J. D. Sterman. System dynamics modeling: tools for learning in a complex world. *California Management Review*, 43(4):8–25, 2001.
- T. Suhonen and T. Amberla. Pöyry’s “World Fibre Outlook up to 2030”: new edition released. URL <https://www.poyry.com/news/poyrys-world-fibre-outlook-2030-new-edition-released>. Accessed 2020-05-13.

- Suomen ilmastopaneeli and Suomen ympäristökeskus SYKE. Autokalkulaattori, 2019. URL <https://www.ilmastopaneeli.fi/autokalkulaattori/>. Accessed 2020-04-29.
- T. Tasanen. Läksi puut ylenemähän: Metsien hoidon historia Suomessa keskiajalta metsäteollisuuden läpimurtoon 1870-luvulla (translation: Läksi puut ylenemähän: The history of silviculture in finland from the mediaeval to the breakthrough of forest industry in 1870s). 2004.
- Technical Association of the Pulp & Paper Industry Inc. How is Paper Recycled, 2001. URL https://web.archive.org/web/20111130061422/http://www.tappi.org/paperu/all_about_paper/earth_answers/EarthAnswers_Recycle.pdf.
- Tilastokeskus. Yhdyskuntajättekertymä 2018, 2018. URL www.stat.fi/til/jate/2018/jate_2018_2020-01-15_tau_001_fi.html. Accessed 2020-04-28.
- A. J. Trappey, C. V. Trappey, C.-T. Hsiao, J. J. Ou, and C.-T. Chang. System dynamics modelling of product carbon footprint life cycles for collaborative green supply chains. *International Journal of Computer Integrated Manufacturing*, 25(10):934–945, 2012.
- United Nations. Sustainable Development Goals. URL <https://www.un.org/sustainabledevelopment/sustainable-development-goals/>. Accessed on 2020-04-27.
- United States Environmental Protection Agency (EPA). Waste Reduction Model (WARM). URL <https://www.epa.gov/warm>. Accessed 2020-04-29.
- University of Helsinki. Hiilijalanjalkilaskuri, 2019. URL <https://blogs.helsinki.fi/hiilifiksu/laskuri/>.
- UPM. UPM Responsibility, a. URL <https://www.upm.com/responsibility/>. Accessed 2020-04-29.
- UPM. Circular Economy, b. URL <https://www.upm.com/responsibility/circulareconomy/>. Accessed on 2020-04-27.
- UPM. The family tree of UPM-Kymmene Corporation, 2019. URL https://www.upm.com/siteassets/asset/about-us/history/upm_kymmenen-familythree_eng_190906.pdf. Accessed on 2020-02-24.

- B. Wohner, N. Schwarzinger, U. Gürlich, V. Heinrich, and M. Tacker. Technical emptiability of dairy product packaging and its environmental implications in Austria. *PeerJ*, 7:e7578, 2019.
- World Bank. Solid Waste Management, 2019. URL <https://www.worldbank.org/en/topic/urbandevelopment/brief/solid-waste-management>. Accessed 2020-05-12.
- M. Yearworth. A Brief Introduction to System Dynamics Modelling (pp. 15), 2014. Accessed 2020-05-04.
- B. Zeide. Analysis of growth equations. *Forest Science*, 39(3):594–616, 1993.

A Appendix

A.1 Simulink Model

A.1.1 Simulink Model – intermediate steps

Figures 9 to 13 show the development process of the Simulink model during the different development phases outlined in Section 3.4. The subsystems are only shown as shadows inside their respective blocks, to save space they are not shown in separate figures.

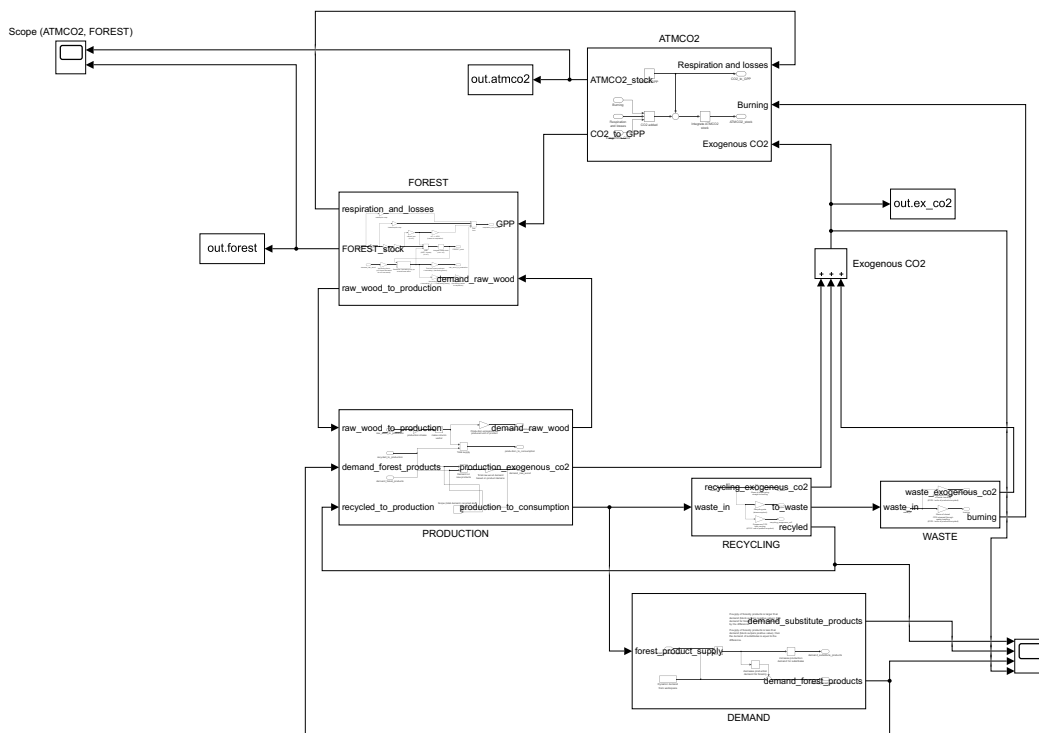

Figure 9: Block diagram of the Simulink model after development phases 1–4 (see Section 3.4).

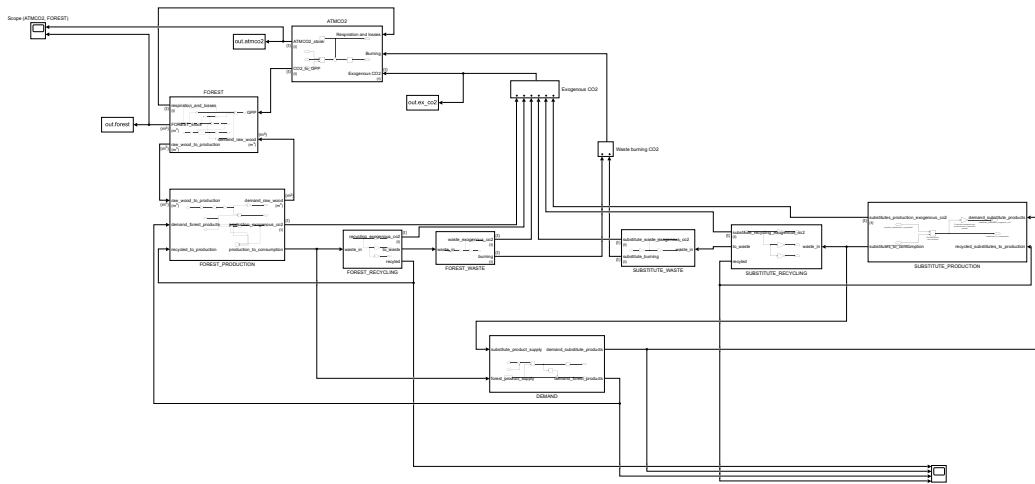

Figure 10: Block diagram of the Simulink model after development phase 5 (see Section 3.4).

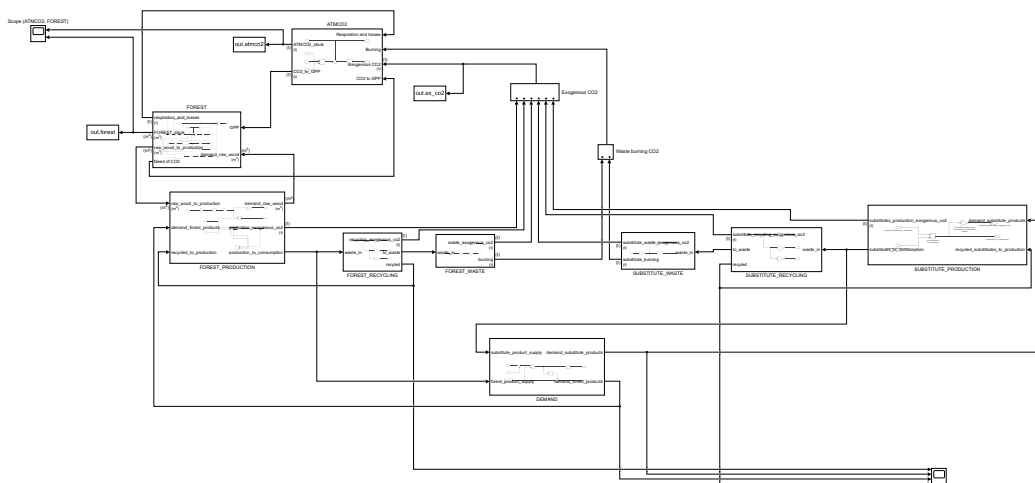

Figure 11: Block diagram of the Simulink model after development phase 6 (see Section 3.4).

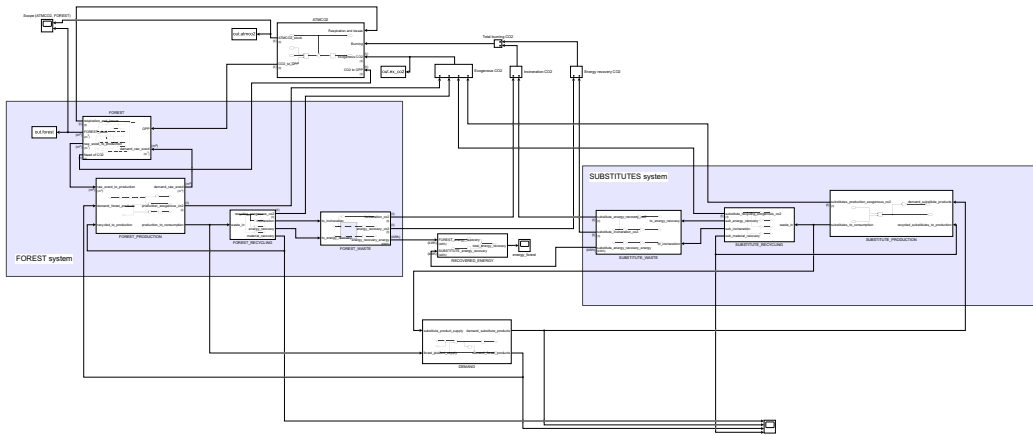

Figure 12: Block diagram of the Simulink model after development phase 7 (see Section 3.4).

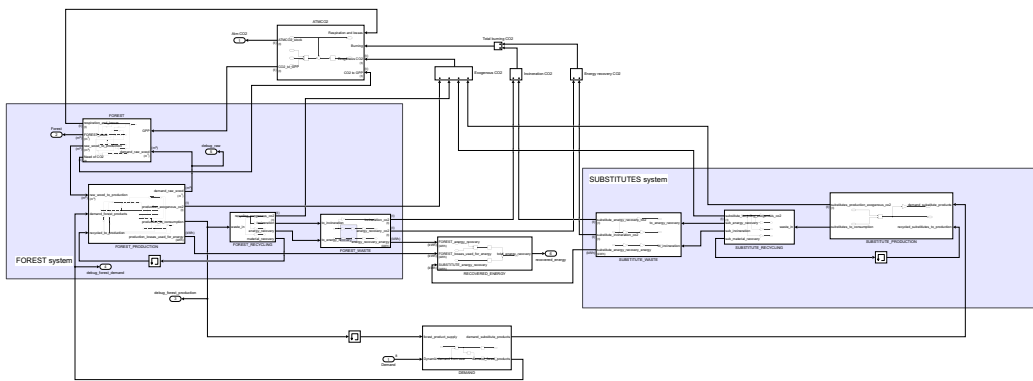

Figure 13: Block diagram of the Simulink model after development phase 9 (see Section 3.4).

A.1.2 Simulink Model – final model

Figure 14 shows the top level diagram of the final Simulink model. Figures 15 to 26 show each of the subsystems of the top level diagram.

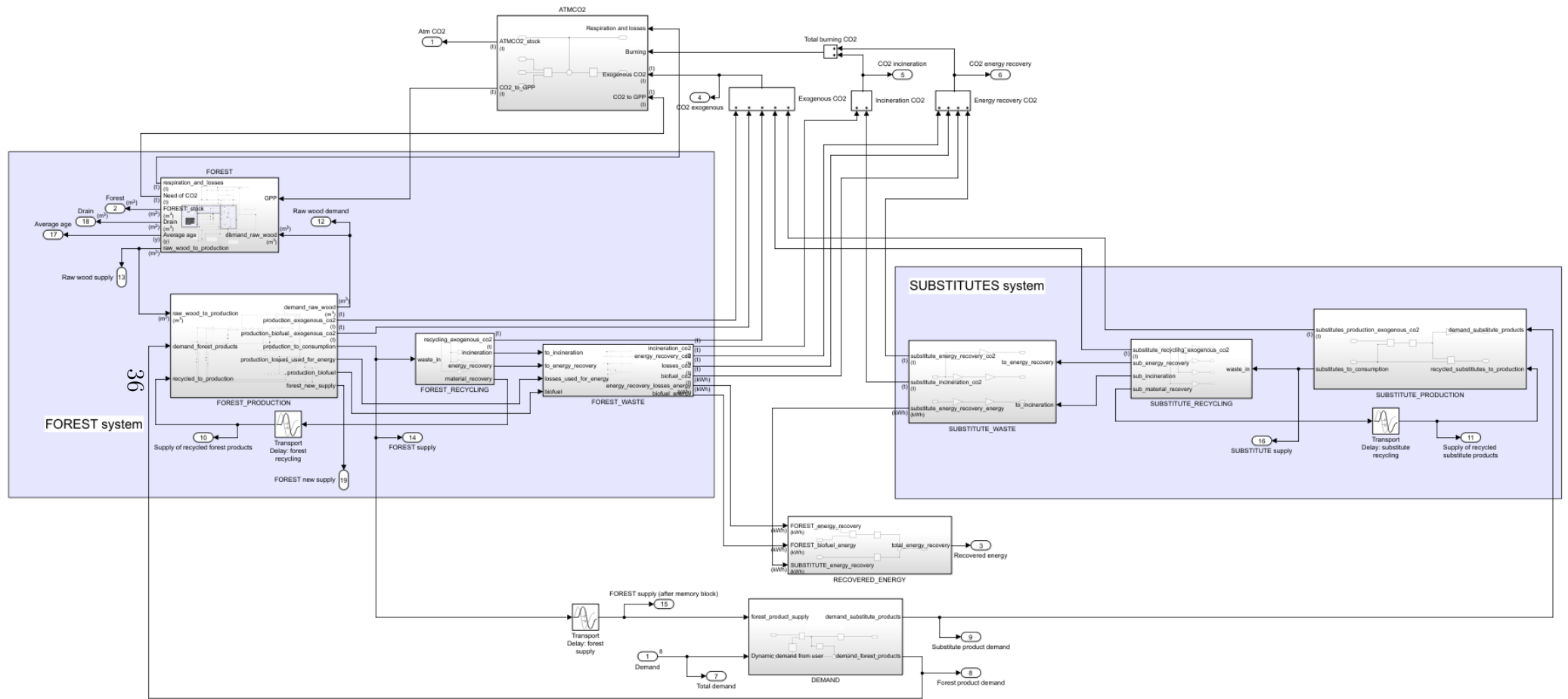

Figure 14: Top level block diagram of the final Simulink model.

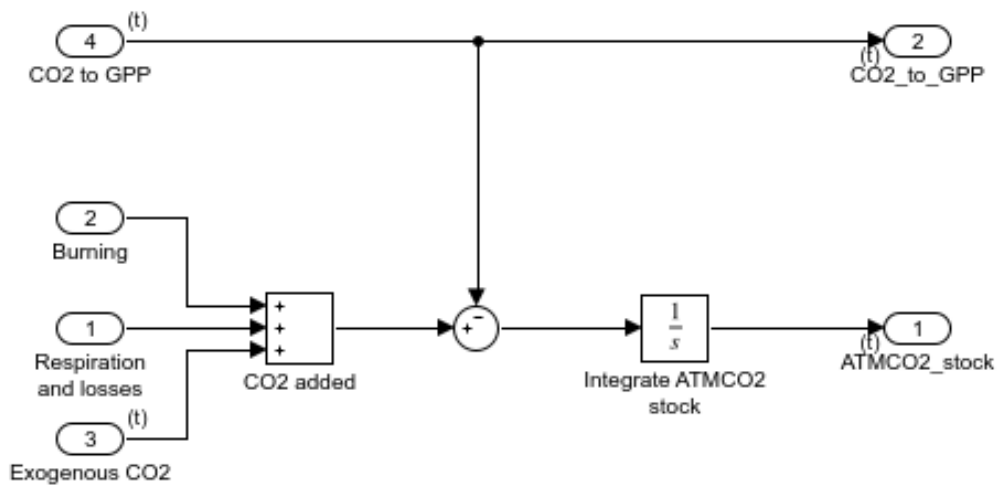

Figure 15: Block diagram of the Simulink model's subsystem ATMCO2.

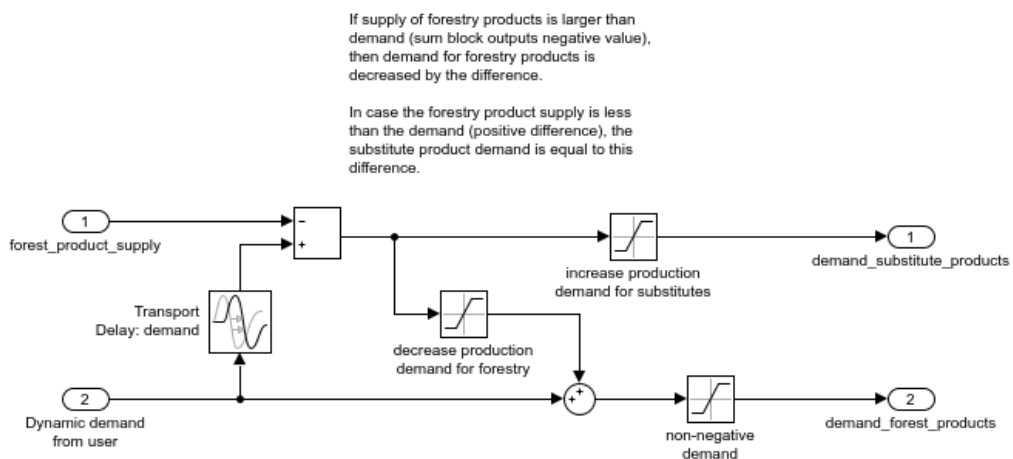

Figure 16: Block diagram of the Simulink model's subsystem DEMAND.

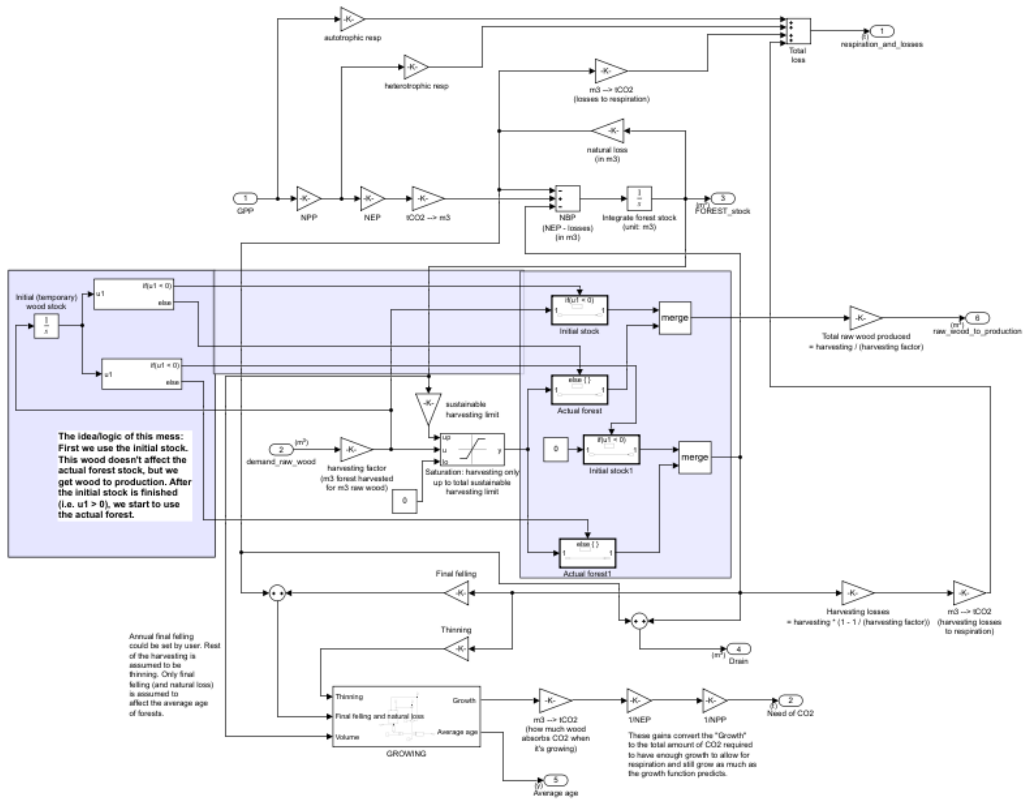

Figure 17: Block diagram of the Simulink model's subsystem FOREST.

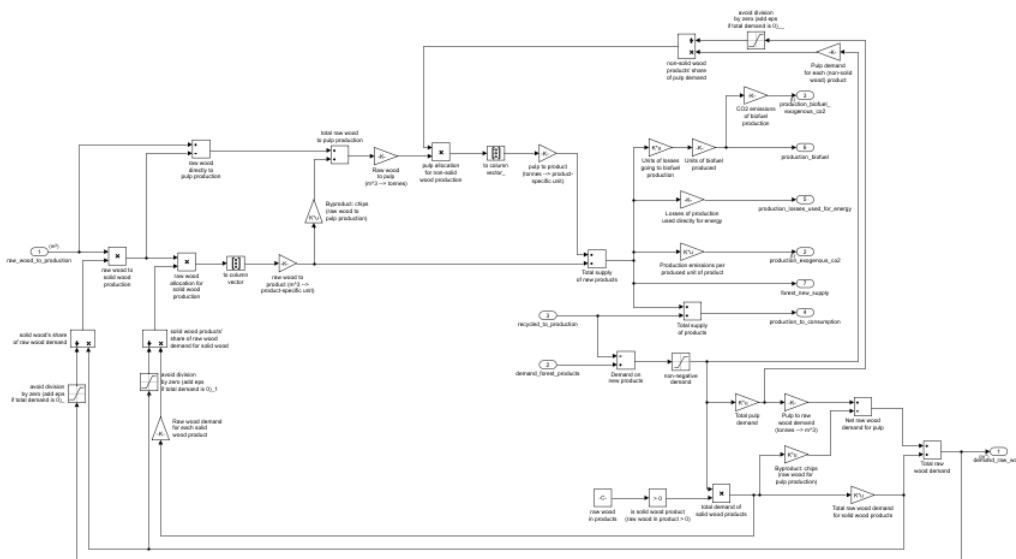

Figure 18: Block diagram of the Simulink model's subsystem FOR-EST_PRODUCTION.

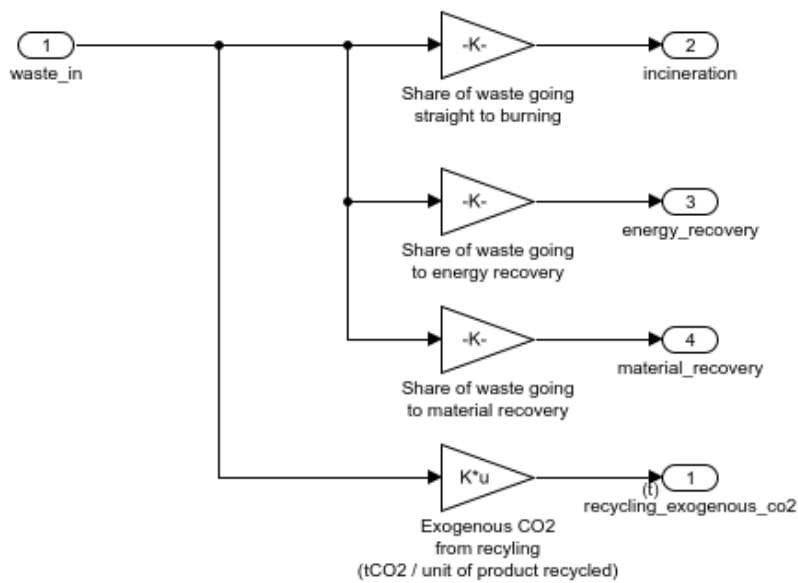

Figure 19: Block diagram of the Simulink model's subsystem FOR-EST_RECYCLING.

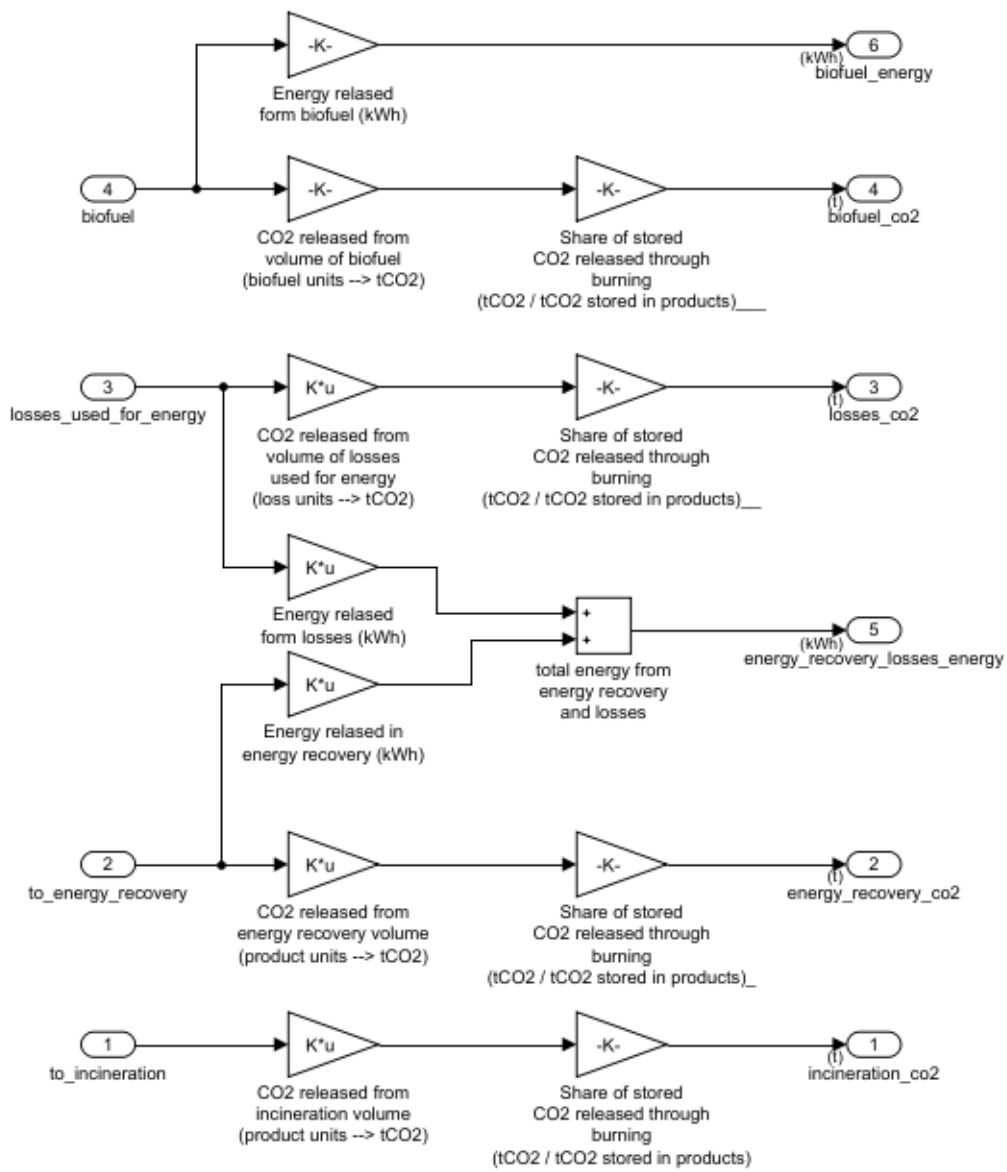

Figure 20: Block diagram of the Simulink model's subsystem FOREST_WASTE.

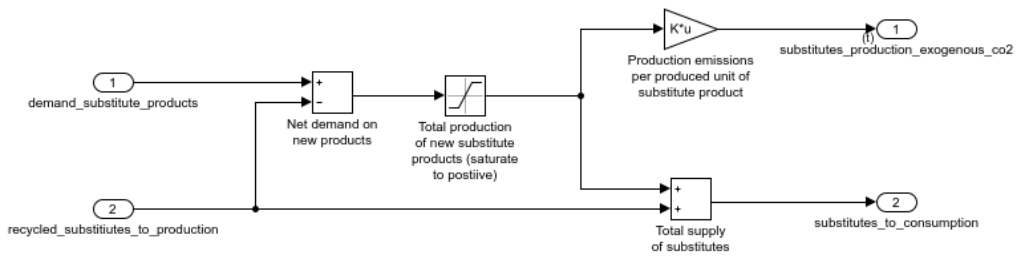

Figure 21: Block diagram of the Simulink model's subsystem SUBSTITUTE.PRODUCTION.

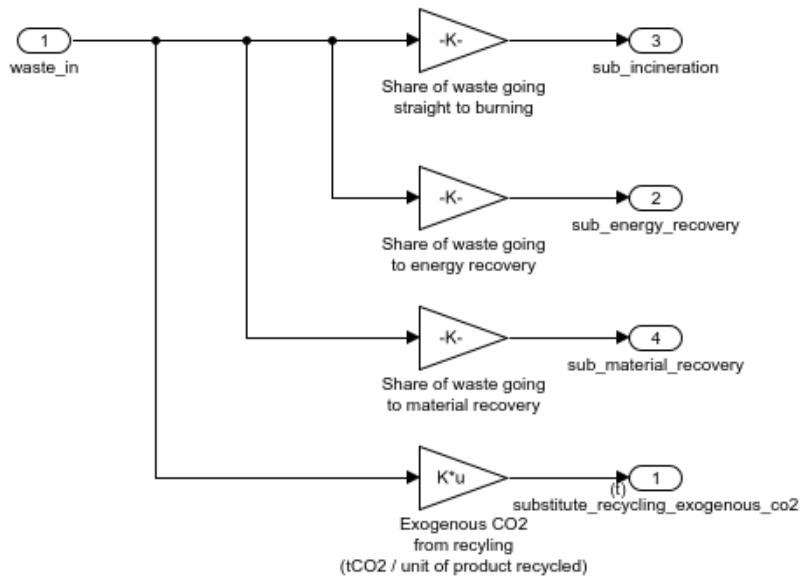

Figure 22: Block diagram of the Simulink model's subsystem SUBSTITUTE.RECYCLING.

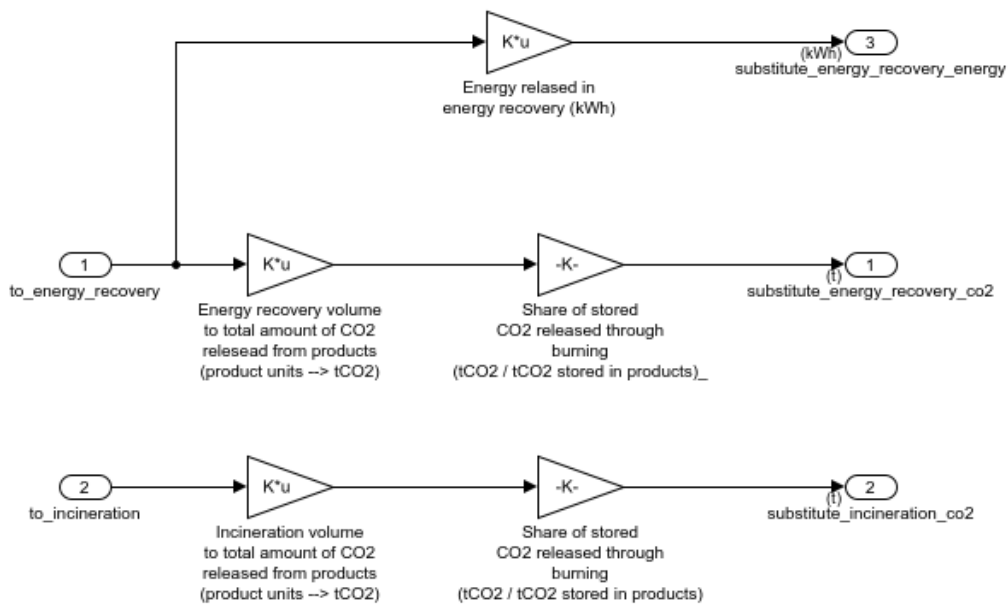

Figure 23: Block diagram of the Simulink model's subsystem SUBSTITUTE_WASTE.

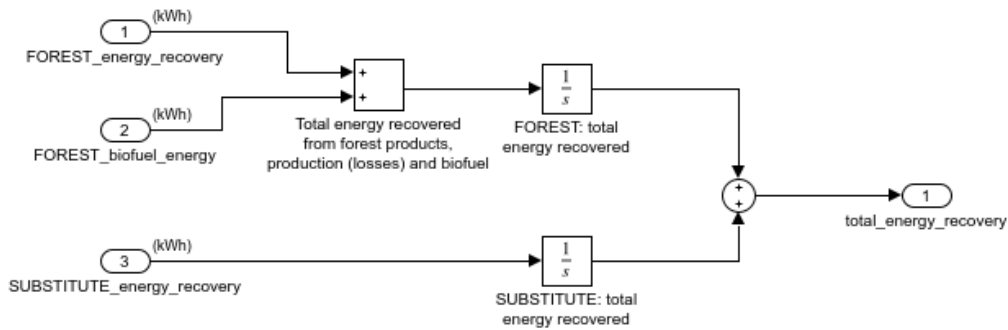

Figure 24: Block diagram of the Simulink model's subsystem RECOVERED_ENERGY.

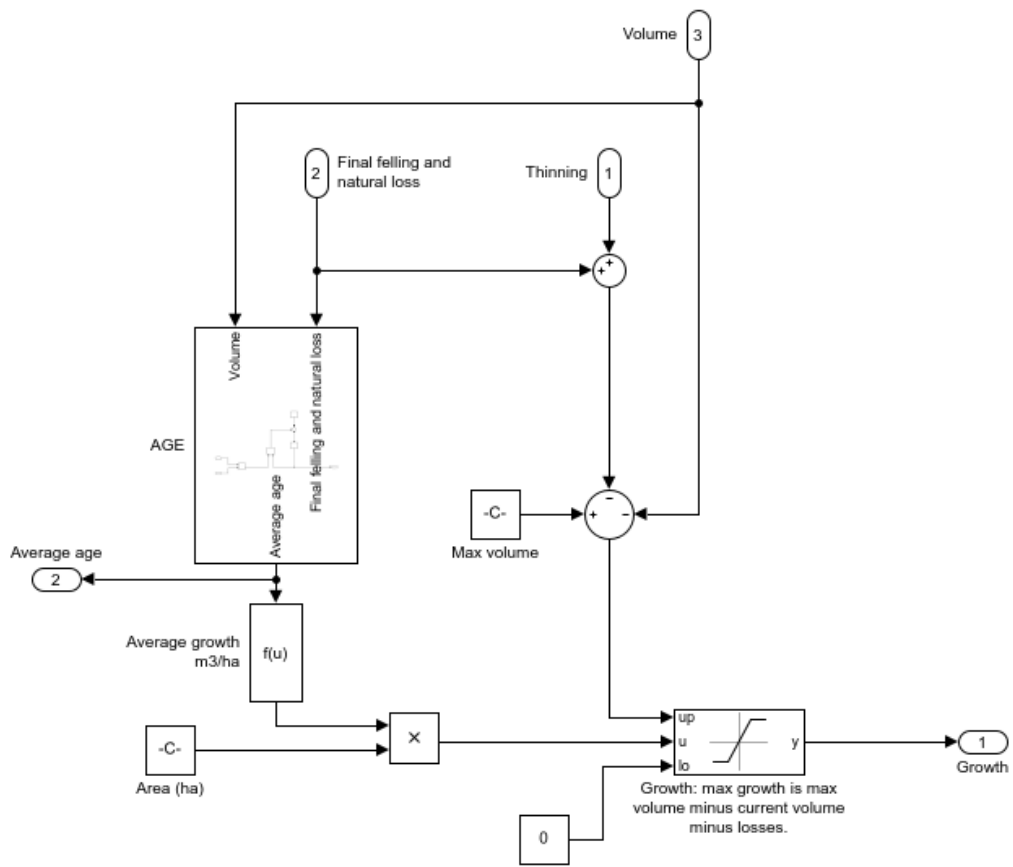

Figure 25: Block diagram of the Simulink model's subsystem GROWING (inside FOREST).

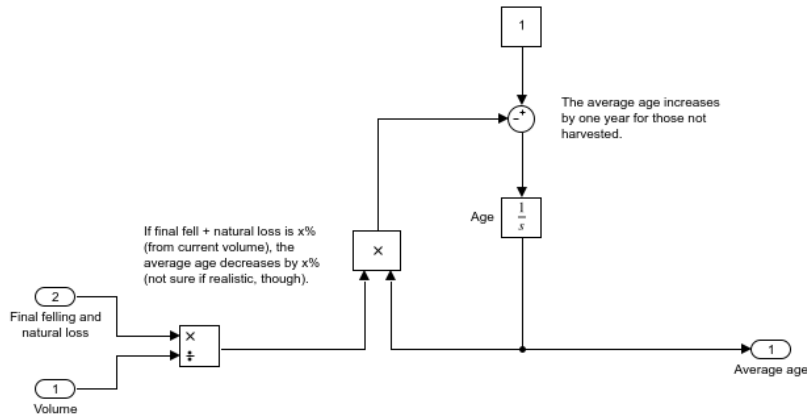

Figure 26: Block diagram of the Simulink model’s subsystems AGE (inside GROWING, which is inside FOREST).

A.2 Substitutions

Substitutions are compared by finding the number of products that can be made from the given unit (tonnes or m^3) and then working out the CO_2 cost for making the same amount of products for substitution data. This means that for 1 tonne of packaging paper we consider to be 2000 paper wraps, giving 2000 plastic trays adding to 0.8 tonnes of LDPE.

Table 3: Comparison Products Weight Comparison

Material	Unit in the System	Number of Items	Comparison Material	Number of Items	Amount of Material
Sawn Wood	1 m^3	50 boards	HDPE Plastic	50 boards	1 m^3
Plywood	1 m^3	50 boards	HDPE Plastic	50 boards	1 m^3
Packaging Paper	1 tonne	2000 paper wraps	LDPE Plastic	0.8 tonnes	
Packaging Paper	1 tonne	2000 paper wraps	HDPE Plastic	0.9 tonnes	
Packaging Paper	1 tonne	2000 1 litre Carton	Glass Bottle	15 tonnes	
Packaging Paper	1 tonne	2000 500ml Carton	Aluminium Can	1.2 tonnes	

A.3 Demand Functions

Demand formulas used in the model. With t as time-step of the model starting from $t = 0$, year = 2019.

Sawn Wood

$$\frac{d_0}{113300000}(58122.12544t) + d_0$$

Plywood

$$\frac{d_0}{1090000}(14159.47179t) + d_0$$

Packaging Paper

$$\frac{d_0}{4800000}(100800t) + d_0$$

Graphic Paper

$$\frac{d_0}{4538000} (9.2686 \cdot 10^{259}(2019 + t)^{-76.6235818} - 9.2686 \cdot 10^{259} \cdot 2019^{-76.6235818}) + d_0$$

Tissue Paper

$$\frac{d_0}{162000} (1.98 \cdot 10^{41}(2019 + t)^{-10.9158334} - 1.98 \cdot 10^{41} \cdot 2019^{-10.9158334}) + d_0$$

A.4 Production Data Values and Sources

The numbers listed below are directly used in the model unless otherwise stated.

In terms of the UPM data we received the Table 4 of 2019 values along with the side-flow of consumption of saw-milling and plywood being 13,945,000 m³ (approximately half of the initial sawn lumber and plywood volume) and the side-flow consumption of pulp giving 120,000t of tall oil, which is then converted into 120,000t of bio-diesel. Plenty of these manufacturing values are also available in UPM's Environmental Certificates. Metsä Wood's tissue cost does not have an official value, but is certified by environmental certifications, therefore the certification upper bound was taken as the manufacturing value (Nordic Ecolabelling [2011-2022], European Union [2019a]).

Because the construction of the production predictions was based on Luke data [Luonnonvarakeskus, 2019], Plywood and Sawn Wood 2019 values are 109,000 m³ and 11,330,000 m³, which are similar to the data provided by UPM.

Table 4: Data from UPM for the year 2019

Product	Harvested Finnish Wood, m3	Production in Finland	Pulp Consumption, tonne	Bark (b) or Lignin (l) Loss	Manufacture and Transport kg CO2 per Unit of Production	Recycling Cost
Sawn Lumber	25256000	12628000 (m3)	0	10 % (b)	31	0
Plywood	2634000	1317000 (m3)	0	10 % (b)	1667.75	0
Packaging and Specialty	0	4800000 (t)	0.37		373.75	1050
Graphic Paper	6439000	4538000 (t)	0.36	10 % (b)	373.75	1050
Tissue Paper	0	162000 (t)	0.68		1100 (Metsä Wood)	0
Energy	7586000	15172000 (MWH)	0		0	0
Pulp Produced	26750000	8300000 (t)	0	23% (l)	366.67	0
Exported Pulp	13497470	4177000 (t)	0	23% (l)	366.67	0
Biofuels	0	120000 (t)	0		740	0

Table 5: Recycling Data from Dahlbo et al. [2011] including transport and recycling into a new product

Material	Carbon Emissions
Paper	1.05 tonnes per tonne
Metal	0.13 tonnes per tonne
Glass	0.57 tonnes per tonne
Plastic	2.33 tonnes per tonne

Table 6: Recycling Rates from Tilastokeskus [2018]

Material	Material Recovery	Energy Recovery	Incineration
Paper	0.929	0.071	0
Metal	0.999	0	0.001
Glass	0.887	0.112	0.001
Plastic	0.631	0.360	0.008

Table 7: Carbon and Energy Data from Phyllis2 [2020]

Name	Name in System	Carbon Content, wt%	Net Calorific Value, MJ/kg
Diesel Oil (#1468)	Diesel Oil	86.50	42.82
Biodiesel (#1509)	Loses used for biofuel	51.41	23.86
Wood Birch + Maple (#68)	Swan Lumber / Plywood	44.87	16.26
Paper, Mixed Office Paper, Pellet (#1509)	Graphic Paper, tissue paper	UPM Value Used	13.25
Paperboard (#2168)	Packing Paper	UPM Value Used	14.07
Bark (#1409)	Loses Used For Fuel	41.01	18.71

Table 8: Data used within and in validation of our model

Value	Use	Source Type	Used or Reference	URL
Plastic Lumber				
1.600 kg CO2 per kg	Plastic lumber production and drilling	Used	Company	www.geosynthetica.com/carbon-footprint-hdpe-geomembranes/
1.478 kg CO2 per kg	Plastic lumber production and drilling	Used	Company	info.dordan.com/hs-fs/hub/194012/file-19954038-pdf/docs/environmental_tech_brief_hdpe.pdf
1.539 kg CO2 per kg	Average Value Used By The Model			
High Density Polythene (HDPE)				
1.8 kg CO2 per kg	HDPE Granulated including extraction	Used	European Database	https://www.plasticseurope.org/en/resources/eco-profiles
1.5299111 kg CO2 per kg	HDPE Virgin Packaging including extraction	Used	American Database	https://www.epa.gov/sites/production/files/2016-03/documents/warm_v14_containers_packaging_non-durable_goods_materials.pdf
0.493615005 kg CO2 per kg	HDPE 100% Recycled Packaging including extraction	Reference	American Database	https://www.epa.gov/sites/production/files/2016-03/documents/warm_v14_containers_packaging_non-durable_goods_materials.pdf
0.51704 kg CO2 per kg	HDPE manufacturing process	Used	Research Paper	https://www.researchgate.net/publication/257408797_Carbon_footprint_analysis_in_plastics_manufacturing
0.9615 kg CO2 per kg	HDPE Virgin Average Value Used By The Model			
0.4936 kg CO2 per kg	HDPE Recycling Average Value			
Low Density Polythene (LDPE)				
1.87 kg CO2 per kg	LDPE Granulated including drilling	Used	European Database	https://www.plasticseurope.org/en/resources/eco-profiles
1.794184417 kg CO2 per kg	LDPE Virgin Packaging including extraction	Used	American Database	https://www.epa.gov/sites/production/files/2016-03/documents/warm_v14_containers_packaging_non-durable_goods_materials.pdf
2.13 kg CO2 per kg	LDPE Production	Used	VTT Database	https://www.vttresearch.com/sites/default/files/pdf/technology/2013/T115.pdf
1.9314 kg CO2 per kg	LDPE Virgin Average Value Used By The Model			
Plastic				
2.10 kg CO2 per kg	Plastic Average	Reference	Research Paper	https://norden.diva-portal.org/smash/get/diva2:839864/FULLTEXT03.pdf
1.30 kg CO2 per kg	Recycled Plastic Average	Reference	Research Paper	https://norden.diva-portal.org/smash/get/diva2:839864/FULLTEXT03.pdf
Aluminum				
12 kg CO2 per kg	Aluminium Virgin	Used	American database	https://www.epa.gov/sites/production/files/2016-03/documents/warm_v14_containers_packaging_non-durable_goods_materials.pdf
2.37 kg CO2 per kg	Aluminium Recycled	Reference	American Database	https://www.epa.gov/sites/production/files/2016-03/documents/warm_v14_containers_packaging_non-durable_goods_materials.pdf
7.10 kg CO2 per kg	Aluminum Virgin to Sheet	Reference	European Database	https://www.european-aluminium.eu/media/2052/european-aluminium-environmental-profile-report-2018-executive-summary.pdf
11 kg CO2 per kg	Aluminium Virgin	Used	Nordic Study	https://norden.diva-portal.org/smash/get/diva2:839864/FULLTEXT03.pdf
0.4 kg CO2 per kg	Aluminium Recycled	Reference	Nordic Study	https://norden.diva-portal.org/smash/get/diva2:839864/FULLTEXT03.pdf
11.498	Aluminium Packaging Virgin Average Value Used By The Model			
1.38	Aluminium Packaging Recycled Average Value			
Glass				
0.42 kg CO2 per kg	Glass Packaging Virgin	Used	American Database	https://www.epa.gov/sites/production/files/2016-03/documents/warm_v14_containers_packaging_non-durable_goods_materials.pdf
0.3 kg CO2 per kg	Glass Packaging Recycled	Reference	American Database	https://www.epa.gov/sites/production/files/2016-03/documents/warm_v14_containers_packaging_non-durable_goods_materials.pdf
0.62 kg CO2 per kg	Glass Bottle (469g)	Used	Study	
0.59 kg CO2 per kg	Glass Bottle (365g)	Used	Study	
0.9 kg CO2 per kg	Glass Virgin packaging	Used	Nordic Study	https://norden.diva-portal.org/smash/get/diva2:839864/FULLTEXT03.pdf
0.92 kg CO2 per kg	Glass packaging	Used	Austrian Study	Wohner et al. [2019]
0.864 kg CO2 per kg	Glass Packaging Virgin Average Value Used By The Model			
0.30 kg CO2 per kg	Glass Packaging Recycled Average Value			

Self Assessment

Overall our team worked effectively together, naturally dividing roles to different members and working on problems as they came up – such as a small lapse in communication when the university transitioned into remote working and team member illnesses. These roles did, however, prevent any of us from developing a complete understanding of each aspect of the model and led us to prioritise our areas and sometimes forget the other aspects of the model. However, all worked consistently harder than the allotted credits, showing there was no lack of effort.

The scope of the project remained fairly unchanged over the course of the project. The final results reflect less on the substitution effect of a single change, for example the difference between plywood and plastic lumber, but the difference between total production and partial production of all forest products against all substitution products.

As in the interim report there have been few encounters with the risks of this project. Although most risks are present in our model to a certain degree; for example some areas are complex, some are simplified, adding more complex and consistent data would add to reliability and time has been lost due to COVID-19; these risks are not present to a level where we would consider the project to have failed on any of these counts.

In terms of time management and the schedule, there were no great problems, however not enough time was left for debugging and building the final touches towards the end of the project. This meant that the project, although completed before the deadline, took a lot of our time towards the end. This was, in combination, due to a lot of errors associated with the user interface, which took time away from other aspects of the project. For a future projects we have learnt that more time should be given to the development of the user interface; not necessarily due to the difficulty of the user interface, but to insure that if there are initial problems these do not impact the other aspects of the project. The earlier delays complicated later tasks that depended on the previous ones.

We also experienced occasional set backs whilst waiting for UPM to respond, meaning certain aspects of the model were developed without as much impact as we would have liked, for example the final functionality of the user interface as well as the processing of the wood into products. However, due to these delays being after the COVID-19 outbreak they were understandable. The open nature of our scope also meant that this did not have a great impact in terms of the models final success, just in defining the details.

Overall we have a reliable, realistic model for educational purposes, which UPM were satisfied with and discussed further uses for during our last meeting. In terms of a general understanding of the domain, the model captures the overriding structures of the forest industry, in particular forest growth, and suggests sensible substitutes where available. This is coupled with an intuitive GUI allowing the user to input their own data to truly understand the system better.

This project could always be improved on, as is the nature of system analysis; there will always be another subsystem to add. However in terms of the biggest improvements one would be to fix the demand so it considers both the recycling of substitute and forest products, not just the forest products. Although lifespans go beyond the scope of this project, both the demand and lifespans of the project could be implemented together. Secondly, achieving a realistic harvest without scaling, which could be achieved by adding more products to account for more of the missing demand in our system. These products could have been added had we more time at the end or noticed this problem earlier. Time management is the third biggest problem we have experienced due to differing commitments, the COVID-19 pandemic, illness, as well as not accounting enough time to overcome the unexpected difficulties involved with building the user interface and the sheer size of this topic. In terms of the latter, we could have asked more expertise from the teaching staff to find what their priorities and sources would have been. A lot of time was spent researching every aspect of this problem and finding data, so being given a few good studies could have also saved us time.